



PSG
1700, Léon-Harmel
Québec(Québec)
G1N 4R9

INSTALLATION AND OPERATION INSTRUCTIONS FOR OIL BURNING FURNACE PSG 6000

**READ THIS MANUAL THOROUGHLY
BEFORE OPERATING THE FURNACE**

CERTIFIED WARNOCK HERSEY BY INTERTEK TESTING SERVICES LTD (ITS) IN ACCORDANCE WITH STANDARDS UL-727 AND B140.4-1974.

CAUTION

RISK OF EXPLOSION OR FIRE. FOR YOUR SAFETY: DO NOT STORE OR USE GASOLINE OR OTHER FLAMMABLE LIQUIDS, VAPOURS OR SUBSTANCES IN THE VICINITY OF THIS OR ANY OTHER APPLIANCES.

DO NOT ATTEMPT TO START THE BURNER WHEN EXCESS OIL HAS ACCUMULATED, WHEN THE FURNACE IS FULL OF VAPOUR, OR WHEN THE COMBUSTION CHAMBER IS VERY HOT.

ALWAYS KEEP THE VALVE SHUT OFF IF THE BURNER IS SHUT DOWN FOR AN EXTENDED PERIOD OF TIME.

DO NOT START THE BURNER UNLESS THE BLOWER ACCESS DOOR IS SECURED IN PLACE.

DO NOT TAMPER WITH THE UNIT OR CONTROLS – CALL YOUR SERVICE-MAN.

NEVER BURN GARBAGE OR PAPER IN THE HEATING SYSTEM, AND NEVER LEAVE PAPER OR RAGS AROUND THE UNIT.

WARNING

OIL BURNING FURNACES MUST BE CONNECTED TO A CIMNEY WHICH WILL PROVIDE ADEQUATE DRAUGHT TO ENSURE A PROPER AND SAFE OPERATION OF THE BURNER.

PLEASE SAVE THESE DOCUMENTS!

Table of contents

GENERAL NOTES	4
1. DRAFT AND CHIMNEY	4
2. OIL TANK AND PIPING	4
BURNER PUMP	4
3. APPLIANCE INSTALLATION	5
A- LOCATING THE UNIT.....	5
B. CLEARANCES TO COMBUSTIBLE MATERIALS	5
C- POSITIONING THE APPLIANCE	5
D- PIPE CONNECTOR AND DAMPER.....	5
E- COMBUSTION AIR.....	6
F- ELECTRIC COMPONENTS INSTALLATION	6
G- ELECTRICAL WIRING	6
H- THERMOSTAT	7
I- FAN CONTROL.....	7
J- COMBUSTION SAFETY CONTROL	7
K- COMBUSTION ADJUSTMENT AND VERIFICATION	8
L- ELECTRODES SETTING	9
4- APPLIANCE START-UP	9
5- PROLONGED CLOSING	9
6- ELECTRICAL DIAGRAMS.....	12
7- TECHNICAL DATA	13
8- TECHNICAL DATA	14
LIMITED LIFETIME WARRANTY	17

GENERAL NOTES

INSTALLATION OF FIRED HEATING UNITS SHALL BE IN ACCORDANCE WITH THE REGULATION OF AUTHORITIES HAVING JURISDICTION AND THE CAN/CSA-B139, CSA-C22.1 NFPA-31 AND ANSI/NFPA-70 STANDARDS.

The units are approved for fuel not heavier than No.2 (furnace). Do not use gasoline, crankcase oil or any oil containing gasoline.

Respect the local codes (when in doubt, consult your local heating appliances dealer).

Make sure that the clearances indicated on the certification plate correspond to the specifications in the instruction manual.

Make sure that your furnace is installed in conformity with the instructions on the name plate.

All the controls adjustments must be performed by a qualified technician. The controls settings and the fan speed must be in compliance with the recommendations of the Warm Air Heating and Air Conditioning National Association and must respect the static pressure ranges in the warm air plenum of the furnace.

1. DRAFT AND CHIMNEY

The chimney must conform to the rules of the authorities having jurisdiction and the CAN/CSA B139 M-91 & NFPA 31 standard regarding installation of oil burning heating appliances. The installation of the connecting pipes to the oil unit must be done and approved by a qualified pipe fitter.

The barometric damper provided with the appliance must be properly installed on the flue pipe of the oil unit. The purpose of the damper is to limit the draft, if necessary, in the oil unit evacuation pipe.

2. OIL TANK AND PIPING

The maximum capacity of the tank must be 200 gallons and the tank must be located at least 7 feet from the burner. Local codes will govern the size of the air inlets and filling openings as well as the type of plugs to be used. 1 1/4" IPS and 2" IPS are usually accepted as minimum dimensions for the air intake pipes and fill pipes, respectively. The oil line to the burner must be a 3/8" outside diameter copper tubing for runs up to 50 feet and 1/2" o.d. for longer runs. A manual shut-off valve and an oil filter shall follow in sequence on the oil line between the oil tank and the burner. Be sure that oil line is clean before connecting to the burner. The oil line must be protected adequately to avoid any damage. Installations having the fuel oil tank below the burner level must employ a two pipe fuel supply system with an appropriate fuel oil pump.

BURNER PUMP

The burner is equipped with a single stage pump. When the pump is connected to a single feeder pipe, a maximum rise of 8 feet is allowed. This height is measured from the tank outlet level to the burner inlet.

When the rise is more than 8 feet and not exceeding 10 feet, a by-pass plug (provided with the burner) must be inserted in the pump and an oil return pipe must be installed. ***For more details, see "INSTALLATION INFORMATIONS", Part No. 21844 on the burner pump.***

If the rise is higher than 10 feet, a two stage pump may be required along with an oil return pipe.

3. APPLIANCE INSTALLATION

A- LOCATING THE UNIT

The furnace must be installed in a location where combustion air is available in sufficient quantity. In airtight houses, the installation of an outside air intake might be required. (See details in 3- APPLIANCE INSTALLATION, E- COMBUSTION AIR).

The owner is responsible for ensuring a proper installation to allow a salubrious operation of the appliance.

Position the furnace so that the connecting pipe is as short as possible and limit the use of 90° elbows to a minimum.

Provide sufficient clearance to permit easy access for maintenance of the filters, motors, controls and pipe connectors.

The furnace is not to be installed on a combustible floor.

B. CLEARANCES TO COMBUSTIBLE MATERIALS

MINIMUM INSTALLATION CLEARANCES TO COMBUSTIBLE MATERIALS	
WARM AIR PLENUM AND FIRST 6 FEET OF DUCT	2 in. (51 mm)
PLENUM AFTER THE FIRST 6 FEET	1 in. (25 mm)
REAR	24 in. (610 mm)
SIDES	6 in. (152 mm)
OIL BURNING UNIT FLUE PIPE	9 in. (229 mm)
* FLOOR	0 in. (0 mm)

***A floor protection exceeding the unit 8” on sides and 18” in the front, should be used when installed on a combustible floor.**

C- POSITIONING THE APPLIANCE

For a safe and quiet operation, the furnace must be levelled in both directions. Give each “U” shape block, an equal support so that the weight is evenly distributed. Prior to positioning the furnace, install the rubber supports under each “U” runner

D- PIPE CONNECTOR AND DAMPER

The pipe connecting the furnace to the chimney must be as short as possible. The use of 45° elbows is highly recommended for a better evacuation of the smoke in the chimney. The draught regulator must be installed in a straight length of pipe no more than 18 inches from the furnace exit pipe and adjusted at .02” w.c.

E- COMBUSTION AIR

If the furnace is located in a room, confined in a restraint area, provide a one square foot opening in the room for each gallon per hour of oil consumption.

Take note that an airtight house is liable to lack the fresh air needed for proper combustion, specially if you are using appliances that evacuate air from the house, such as:

- Range hood
- Air exchanger
- Clothes dryer
- Bathroom fan
- Central vacuum cleaning system

In that case, it is recommended to install a 4" fresh air inlet in the room or next to the room where the heating appliance is located (see drawing below); choose a wall which is not exposed to dominant winds, depending on the conditions surrounding your house.

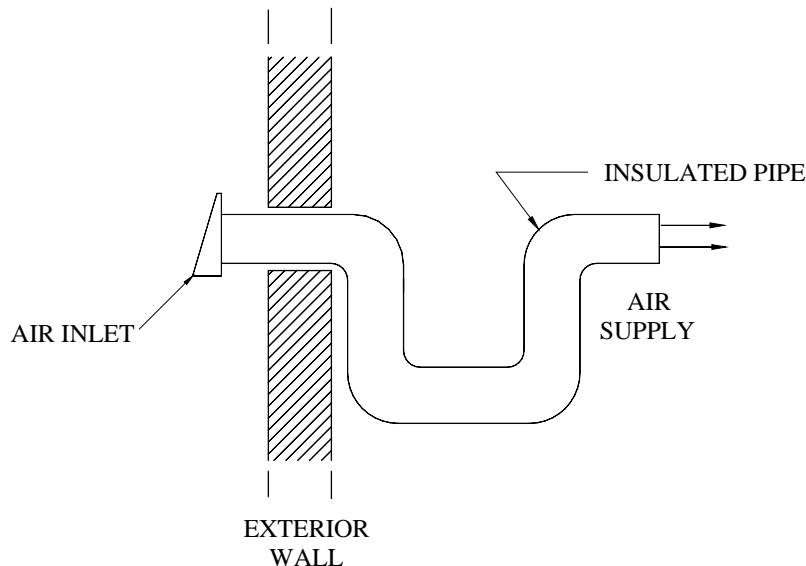

Figure #1

N.B. The owner is responsible for the salubrity of the premises in case of negative pressure or temporary negative pressure.

F- ELECTRIC COMPONENTS INSTALLATION

All the wires joining the electric components must have the proper length. (see figure #1). It is important to keep all wires at a safe distance from hot surfaces.

G- ELECTRICAL WIRING

The whole wiring from the distribution panel to the heating unit shall comply with the applicable electrical standards and local codes. The unit should be connected to its own 15 amp/120VAC electric circuit.

H- THERMOSTAT

Thermostats must be installed on an interior wall, in a location where they are not affected by the air draft coming from the furnace's blower; it must be level and at least 55 inches above the floor.

I- FAN CONTROL

The fan limit control settings may vary according to the type of building and heating installation; the "fan off" setting is factory set at 100°F and this setting should allow a proper operation for most installations. The "fan on" setting should be positioned as close as physically possible to the "fan" off" setting. The high limit must be set at 250°F.

In order for the blower to run for long enough periods, the "fan off" setting must not be set too high but too low a setting will result in undesirable cold air circulation. To modify this setting, turn the indicator to the desired position on the temperature scale of the fan limit control.

All adjustments of the controls must be performed by a qualified technician. The controls settings and the blower speeds must be set in accordance with the recommendations of the Warm Air Heating and Air Conditioning National Association.

To obtain a continuous air circulation during summer months, simply turn the manual switch on the fan limit control from the "auto" to the "manual" position.

A replacement limit control must be identical to that supplied as original equipment.

J- COMBUSTION SAFETY CONTROL

The AFG type oil burner is equipped with an electronic control (# R7184B1032) including a pre-purge/post-purge function and a new more durable drive motor.

PRE-PURGE

When there is a call for heat, the burner's fan will run for 15 seconds before the actual ignition takes place to vent the combustion chamber and generate a proper draft. This will result in a smoother ignition of the oil burner.

SAFE OPERATION

If the flame goes out while the burner is running, the CAD cell will detect it; the control will then switch to the "RECYCLE" mode and cut the fuel supply to the burner for 60 seconds. After this delay, the control goes back to "IGNITION" mode. If the flame goes out 3 times in a row, the control will switch to the "LOCKOUT" mode to prevent a continuous cycling of the ignition process, which would cause a premature sooting of the combustion chamber and smoke pipe. To deactivate the "LOCKOUT" mode, press and hold the reset button of the control for 30 seconds.

A green diagnostic LED on the control has four states:

- On = Flame present
- Off = No flame
- 2 seconds On, 2 seconds Off = "Recycle" mode
- 1/2 second On, 1/2 second Off = "Lockout" mode TEMPORARY SHUT-OFF

By pressing and holding the reset button, the burner will shut-off until the reset button is released. Then, the control will start over at the beginning of the normal cycle.

FOR ADDITIONAL INFORMATIONS ON OPERATION SEQUENCES OF THE BURNER, CONSULT THE BURNER INSTRUCTION MANUAL.

K- COMBUSTION ADJUSTMENT AND VERIFICATION

To enjoy the efficiency of our oil burning units, you must respect the following criterias:

TOOLS REQUIRED:

- DRAFT GAUGE
- SMOKE TESTER
- PUMP PRESSURE GAUGE
- NOZZLE AND ELECTRODES POSITION TESTER
- COMBUSTION TESTER

CHECK LIST:

- SELECTION OF NOZZLE AND HEAD
- NOZZLE / ELECTRODES POSITION IN RELATION TO THE HEAD
- PUMP PRESSURE
- LOW FIRING RATE BAFFLE (INSIDE THE BURNER) REQUIRED FOR PSG6000
- FAN SPEED
- BAROMETRIC DAMPER POSITION
- GASKET BETWEEN BURNER AND FRONT PANEL

COMBUSTION VERIFICATION PROCEDURE:

- A- DRILL A 9/32" DIAMETER HOLE IN THE EVACUATION PIPE APPROXIMATELY 18" FROM THE OUTLET.
- B- LIGHT THE BURNER FOR AT LEAST 10 TO 15 MINUTES.
- C- OVER THE FIRE DRAUGHT = -0.01 TO -0.02 W.C. (THE DRAFT OVER THE FIRE MUST BE MEASURED IN THE OPENING IN THE PULSATION TRAP).
- D- SMOKE TEST BETWEEN 0 AND 1 ON THE SHELL BACHARACH SCALE (TRACES).
- E- DRAFT IN THE CHIMNEY = -0.02
- F- PERCENTAGE OF EXCESS AIR = 20 TO 40%, 12% CO₂, 4.6% O₂.
- G- AVERAGE EFFICIENCY OF 82 TO 85 %.
- H- TIGHTEN ALL THE LOCKING SCREWS AFTER COMPLETING THE FINAL ADJUSTMENT.

N.B. – The barometric damper provided with the appliance must be properly installed on the flue pipe of the oil burning unit. The purpose of the damper is to adjust the draft in the evacuation pipe of the oil burning unit to the recommended level.

L- ELECTRODES SETTING

The electrodes must be adjusted by a qualified technician. A proper positioning of the electrodes is important to get an efficient lighting of the oil.

ELECTRODE SETTING FOR "F" HEAD



Schéma #2

WARNING:

1. REFER TO THE RATING PLATE FOR THE PUMP PRESSURE AND THE NOZZLE TYPE.
2. REFER TO THE BECKETT INSTRUCTION MANUAL FOR DETAILS ON THE BECKETT PUMP.
3. FOR ELECTRODES SETTING SEE THE BECKETT MANUAL.
4. FOR THE START-UP AND ADJUSTMENT OF THE BURNER SEE THE INSTRUCTION MANUAL OF THE BURNER.
5. IN CASE OF BURNER FAILURE, REFER TO THE BURNER MANUAL.

4- APPLIANCE START-UP

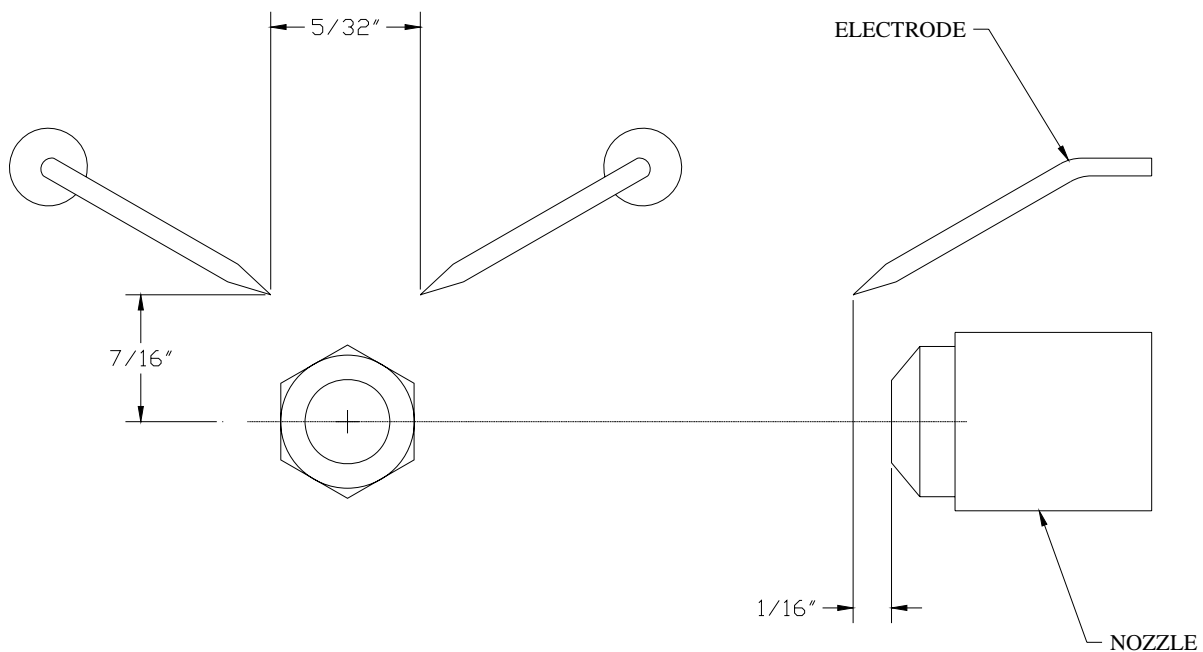
The start-up must be performed by a qualified technician. Make sure the installation is completed and the oil tank has been filled up. The oil line must also have been purged.

CAUTION: CLOSE THE BLOWER COMPARTMENT ACCESS PANEL BEFORE STARTING THE BURNER.

5- PROLONGED CLOSING

- A) Cut off the electric circuit
- B) Close the oil shut-off valve

NOTE: The shut-off valve must be closed when the appliance is out of service for a prolonged period of time.

6- MAINTENANCE (Including filters)

At the beginning of heating season, have the complete installation inspected by a qualified service man, especially the lighting system and the controls.

NOTE: THE UNIT'S MAINTENANCE, REPAIRS AND THE CLEANING OF THE OIL FILTER MUST BE DONE BY A QUALIFIED TECHNICIAN.

SERVICE:

Before calling for service, first check the following:

- Fuel supply
- Electric fuses or breakers
- Thermostat setting
- Fan limit controls settings
- The state of the green diagnostic LED on the burner control
- Reset push button on combustion control and burner motor. **ONCE ONLY.**

MAINTENANCE:

WARNING: *Turn off electric power supply before servicing the unit and close oil valve.*

1. The furnace, the burner and the flue pipe should be cleaned at least once a year.
2. The nozzle should be inspected and replaced if needed.
Handle with care to avoid damaging its surface.
3. The electrodes should be adjusted as indicated in the burner manual.
4. Lubricate the burner motor bearings twice a year.
(2 or 3 drops of SAE 20 non detergent lubricating oil).
5. The oil filter should be replaced annually

Burner no.: _____ Model: _____ Date of installation: _____

Service Telephone no.: Day: _____ Night: _____

Dealer's name and address: _____

TEST REPORT :

CO₂ _____% Temp. at stack: _____ Draft at stack: _____ w.c.

Nozzle output: _____ GPH Smoke colour: _____

Inspected by : _____

FILTERS

The furnace should never be operated without filters.

This applies especially to temporary heating during construction period. Operating the furnace without filters would allow dust and other particles in the air to circulate freely and to penetrate into the fan and motor carters causing some defects. Clean and replace filters as often as required.

Note : The operation cost is higher when using a dirty filter.

6- ELECTRICAL DIAGRAMS

WIRING DIAGRAM FOR PSG6000

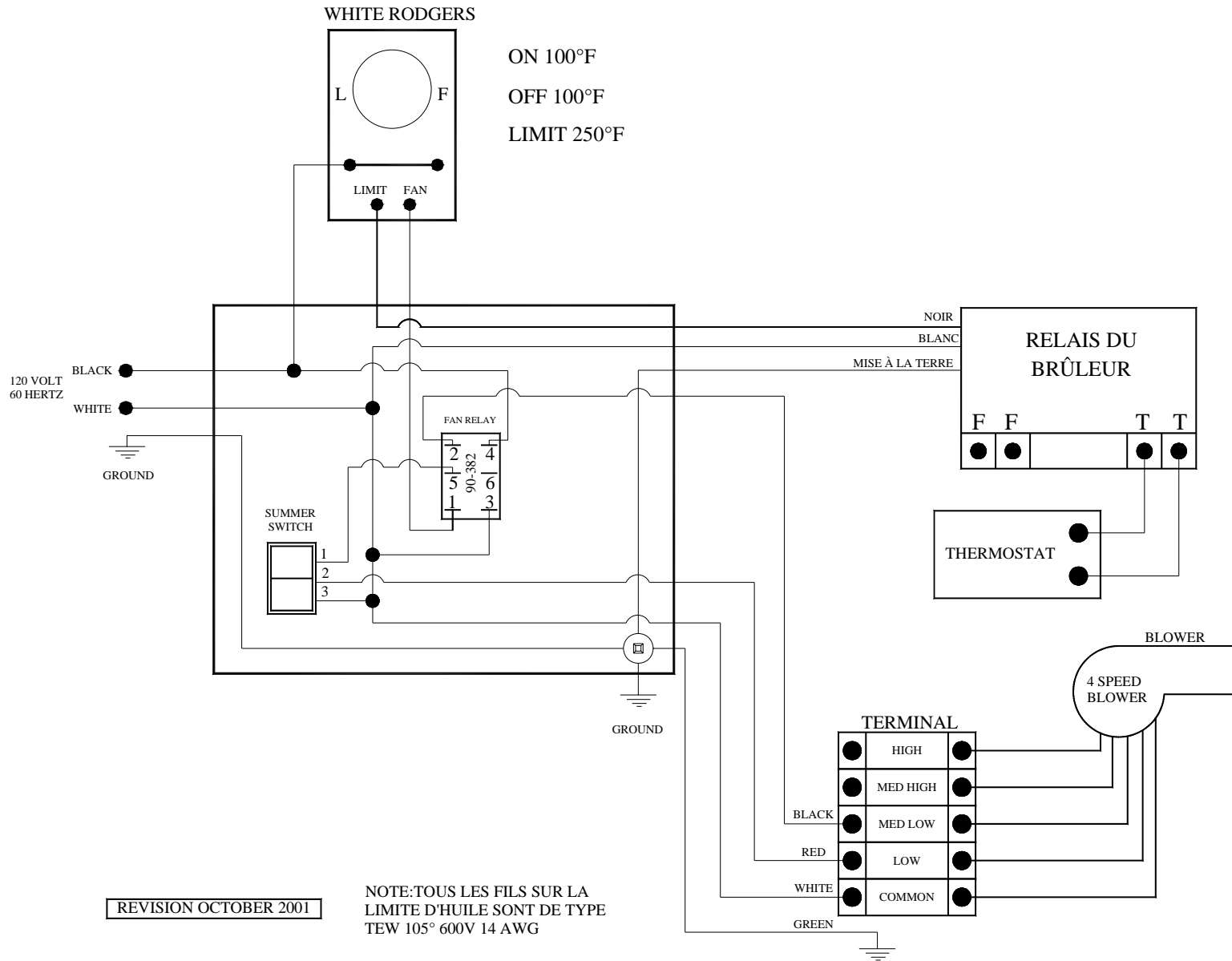

REVISION OCTOBER 2001

7- TECHNICAL DATA

Approved burners for PSG 6000

Note:PSG6000 is only ,manufactured with a Beckett burner, but can be used with all these burner types.

Burner model	BTU input	Nozzle size	End cone	Static disc	Pump pressure	Temp. Rise at .20" w.c.	CFM	Blower speed	Motor H.P.
Beckett AFG	80,000	.50 80 ⁰ B	F0	3 3/8"	140	74 ⁰ F	1000	MED-LO	1/3 HP
	90,000	.50 80 ⁰ B	F0	3 3/8"	160	77 ⁰ F	1100	MED-LO	1/3 HP
	100,000	.65 80 ⁰ B	F0	3 3/8"	130	67 ⁰ F	1400	MED-HI	1/3 HP
	110,000	.65 80 ⁰ B	F3	3 3/4"	160	70 ⁰ F	1500	MED-HI	1/3 HP
	120,000	.65 80 ⁰ B	F3	3 3/4"	170	72 ⁰ F	1600	MED-HI	1/3 HP
RIELLO F3	80,000	.65 80 ⁰ B			100	74 ⁰ F	1000	MED-LO	1/3 HP
	90,000	.65 80 ⁰ B			120	77 ⁰ F	1100	MED-LO	1/3 HP
	100,000	.65 80 ⁰ B			140	67 ⁰ F	1400	MED-HI	1/3 HP
	110,000	.65 80 ⁰ B			160	70 ⁰ F	1500	MED-HI	1/3 HP
	120,000	.65 80 ⁰ B			185	72 ⁰ F	1600	MED-HI	1/3 HP
AERO FAFC 2X	80,000	.50 80 ⁰ B			140	74 ⁰ F	1000	MED-LO	1/3 HP
	90,000	.50 80 ⁰ B			180	77 ⁰ F	1100	MED-LO	1/3 HP
	100,000	.65 80 ⁰ B			140	67 ⁰ F	1400	MED-HI	1/3 HP
	110,000	.65 80 ⁰ B			160	70 ⁰ F	1500	MED-HI	1/3 HP
	120,000	.65 80 ⁰ B			180	72 ⁰ F	1600	MED-HI	1/3 HP

For any additional informations, consult the rating plate on the left hand side of the appliance.

8- TECHNICAL DATA

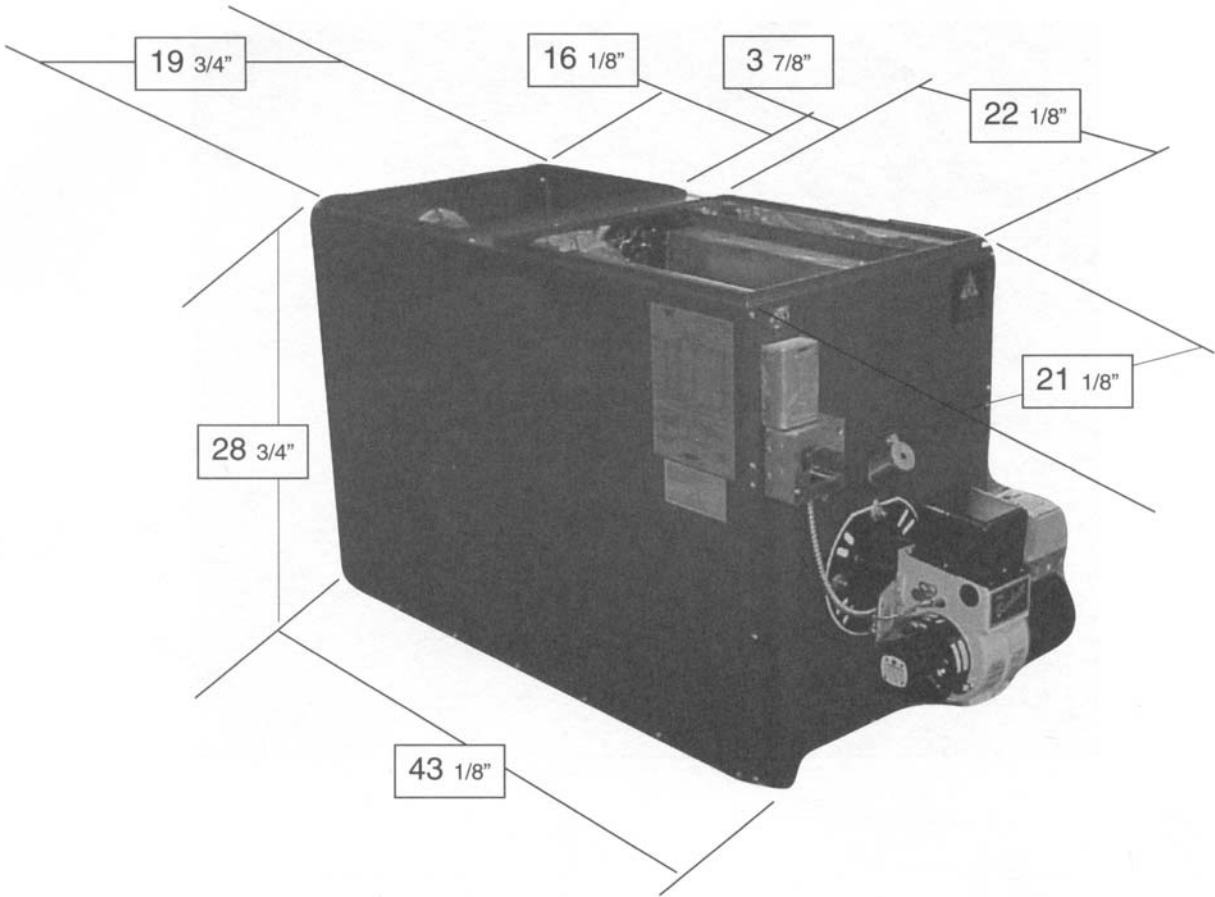

Figure #1

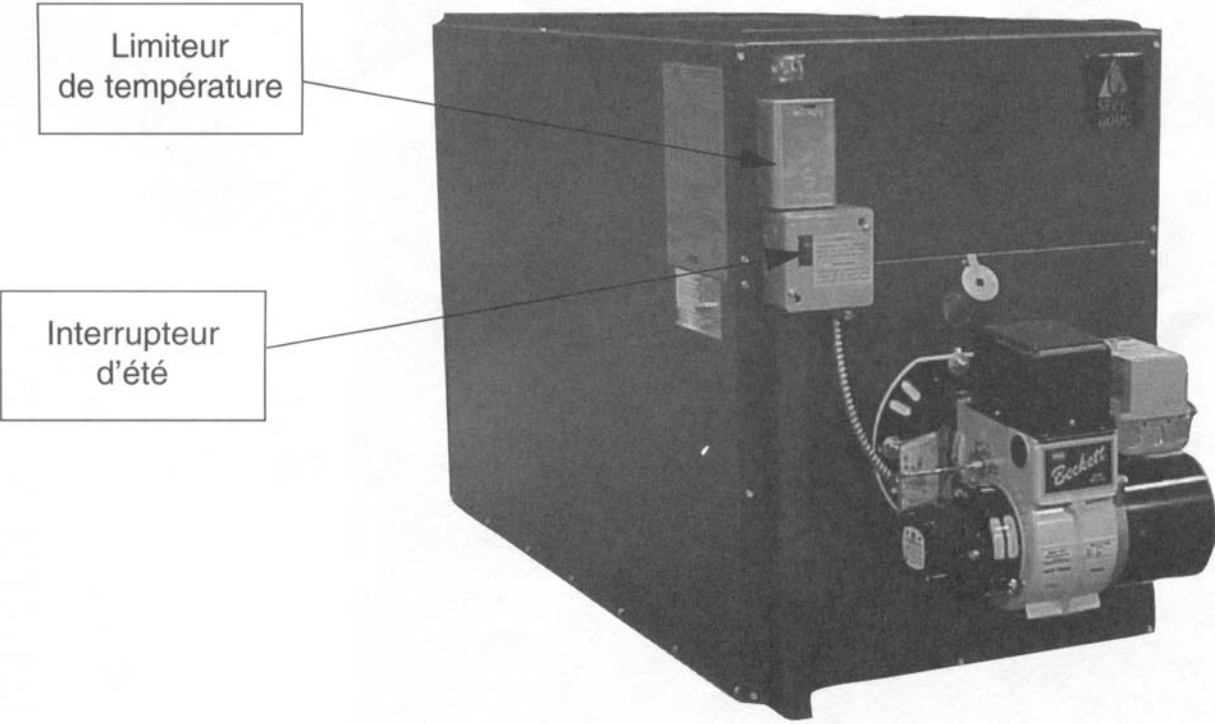
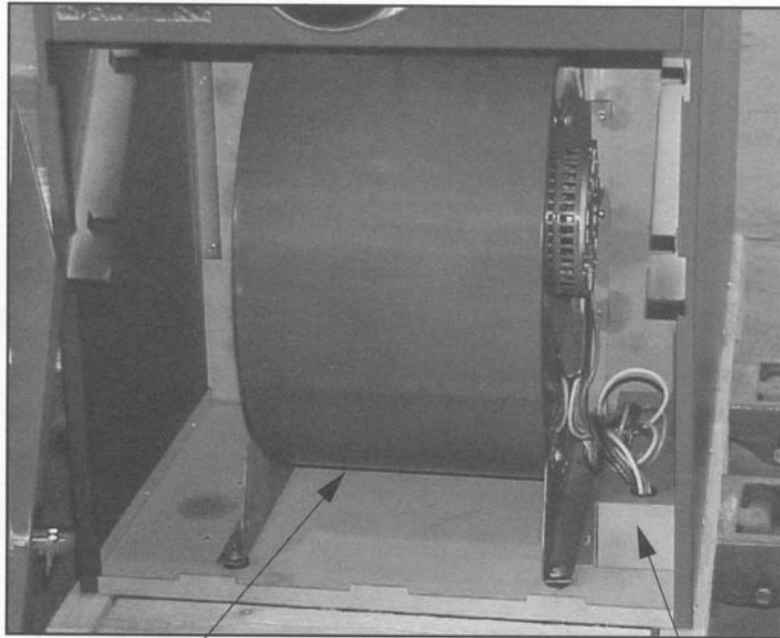

Figure #2



Ventilateur

Boite électrique

Figure #3

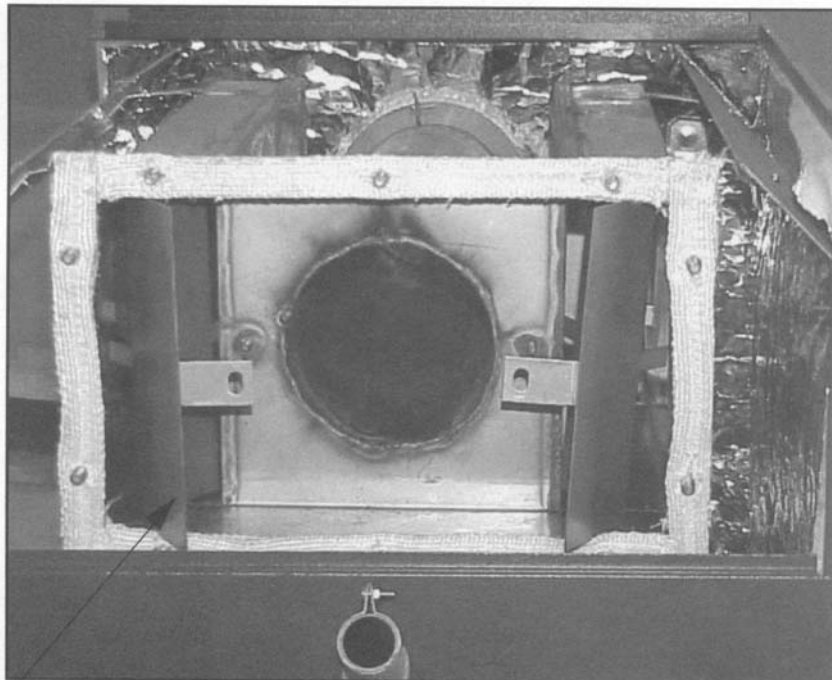

Défecteur
intérieur

Figure #4

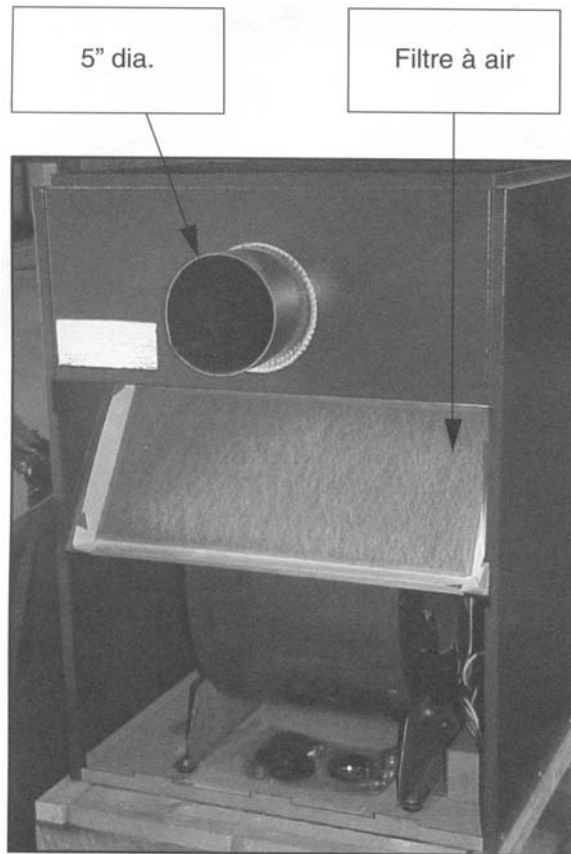

5" dia.

Filtre à air

Figure #5

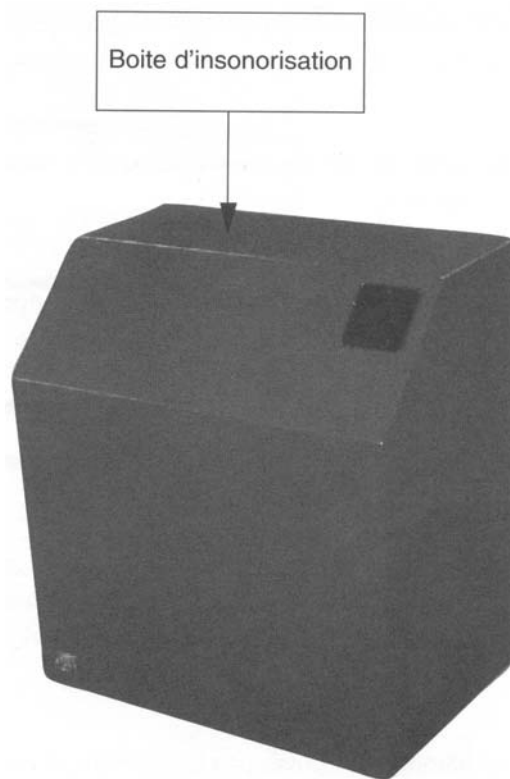

Boite d'insonorisation

Figure #6



1700, rue Léon-Harmel, Québec (Québec) G1N 4R9
 tel. : (418) 527-3060 fax : (418) 527-4311
 e-mail : tech@sbi-international.com web site : www.psg-distribution.com

LIMITED LIFETIME WARRANTY

The PSG warranty extends only to the original consumer purchaser and is not transferable. This warranty covers brand new products only, which have not been altered, modified nor repaired since shipment from factory. Proof of purchase (dated bill of sale), model name and serial number must be supplied when making any warranty claim to your PSG dealer

This warranty applies to normal use only. Damages caused by misuse, abuse, improper installation, lack of maintenance, over firing, negligence or accident during transportation are not covered by this warranty.

This warranty does not cover any scratch or discoloration caused by over firing, abrasives or chemical cleaners. Any defect or damage caused by the use of unauthorized parts or others than original parts void this warranty.

An authorized qualified technician must perform the installation in accordance with the Instructions supplied with this product and all local and national building codes. Any service call related to an improper installation is not covered by this warranty.

Returned products are to be shipped prepaid to PSG for investigation. If a product is found to be defective, PSG will repair or replace such defect and reasonable transportation fees will be refund. Repair work covered by the warranty, executed at the purchaser domicile by an authorized qualified technician requires the prior approval of PSG. Labour cost and repair work to the account of PSG are based on predetermined rate schedule and must not exceed the wholesale price of the replacement part.

PSG at its discretion may decide to repair or replace any part or unit after inspection and investigation of the defect. PSG may, at its discretion, fully discharge all obligations with respect to this warranty by refunding the wholesale price of any warranted but defective parts

PSG shall in no event be responsible for any special, indirect, consequential damages of any nature, which are in excess of the original purchase price of the product.

DESCRIPTION	WARRANTY APPLICATION	
	PARTS	LABOUR
Combustion chamber (weldings only)	Lifetime	5 years
Perforation caused by rust	5 years	n/a
Stainless steel baffle	5 years	1 year
Carbon steel baffle	2 years	1 year
Handle assembly	5 years	n/a
Ash drawer	Lifetime	1 year
Cast iron parts	5 years	1 year
Ceramic glass (thermal breakage only)	1 year	n/a
Paint, refractory bricks, gasket, blower, thermal switch (thermodisc), rheostat and burner	1 year	n/a
Plating	1 year	n/a

Shall your unit or a components be defective, contact immediately your **PSG** dealer. Prior to your call make sure you have the following information necessary to your warranty claim treatment:

- You name, address and telephone number;
- Serial number and model name as indicated on the nameplate fixed to the back of your unit;
- Bill of sale, dealer's name;
- Nature of the defect and any relevant information.

Before shipping your unit or defective component to our plant, you must obtain from your PSG dealer an Authorization Number. Any merchandise shipped to our plant without authorization will be refused automatically and returned to sender.