

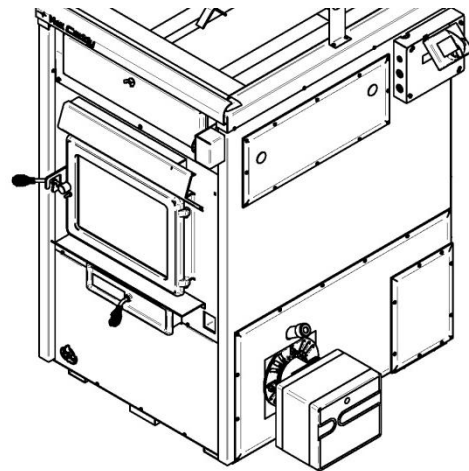

OPTIONAL OIL UNIT INSTALLATION (PA08512 or PA8513) MAX CADDY FURNACE

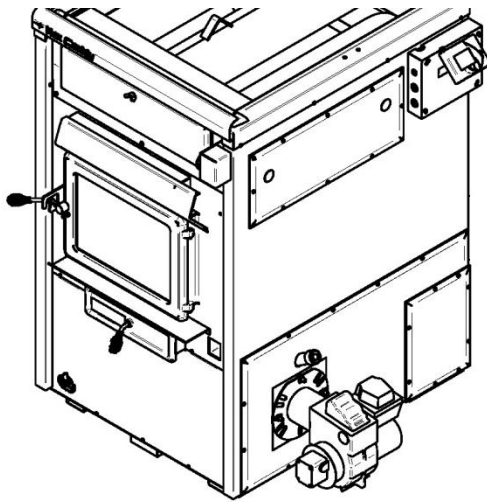

**WARNING: INSTALL THE NOZZLE, ADJUST THE ELECTRODES,
ADJUST PRESSURE ACCORDING TO THE OIL UNIT
MANUFACTURER'S RECOMMENDATIONS.**

**NOTE: IF A PROBLEM RESULTS FROM IMPROPER INSTALLATION,
NO PRODUCT WARRANTY WILL BE VALID.**

Verified and tested for
Canada and the United
States by an accredited
laboratory.



This manual is available for free download on the manufacturer's web site. It is a copyrighted document. Resale is strictly prohibited. The manufacturer may update this manual from time to time and cannot be responsible for problems, injuries, or damages arising out of the use of information contained in any manual obtained from unauthorized sources.



***Eco-energy at the hearth
of your home***

PSG
250, rue de Copenhague,
St-Augustin-de-Desmaures (Québec)
CANADA G3A 2H3

Your Max Caddy furnace can be equipped with an optional oil unit. This option can be installed on either side of your furnace. It is important to note that the default configuration of your furnace features the oil unit installed on the right side of your furnace. It is possible to install the oil unit on the left side but requires additional steps.

Installation must be performed by a qualified technician.

Please note that the installation of the oil unit on the furnace is carried out in an identical way for both Beckett and Riello burner, only the electrical connections differ. For electrical connections, refer to the section ***“Electrical connections”*** and the wiring diagram at the end of the leaflet.

SECTION 1 - INSTALLATION INSTRUCTIONS

Step 1. Remove the left panel and the right panel of the furnace by removing the screws that hold them in place (44X). Keep the screws. Discard the panels marked with an “X”.

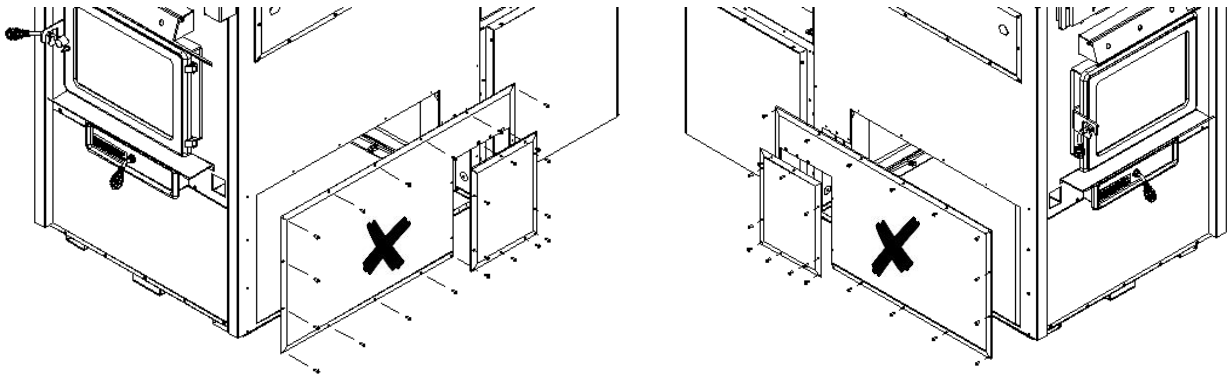

Note: To install the oil unit on the left side of the furnace, replace Step 2 by the Section ***“additional steps for left side installation”***. Continue the installation from Step 3.

Step 2. Install the deflector on the oil unit with the screws (4X) provided with it. Then install the bolts (4X) in the nuts located on the oil unit combustion chamber.

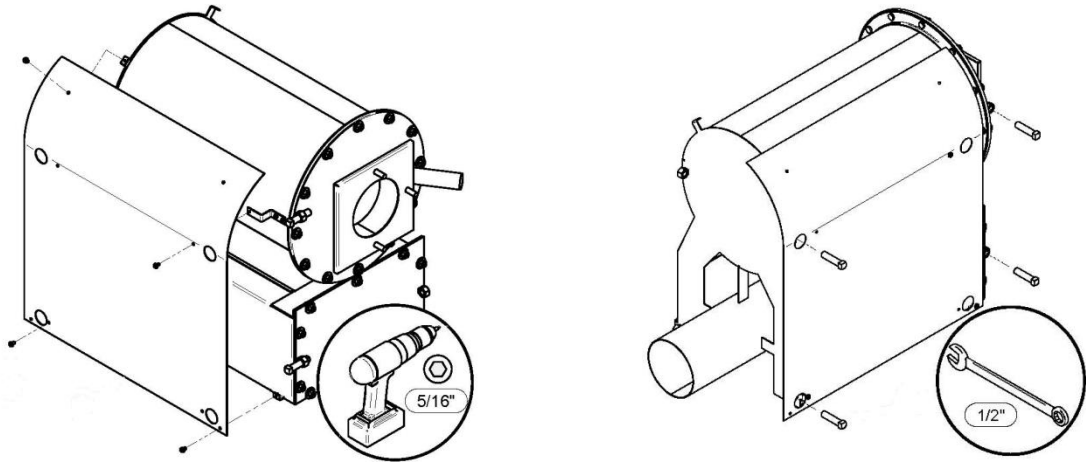

Step 3. Remove the view tube cap.

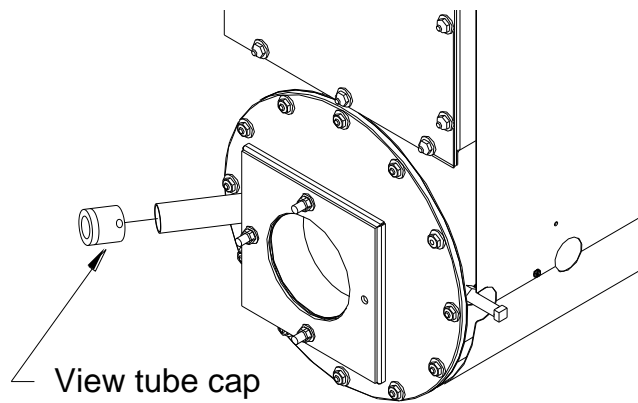

Step 4. Slide the oil unit in the furnace.

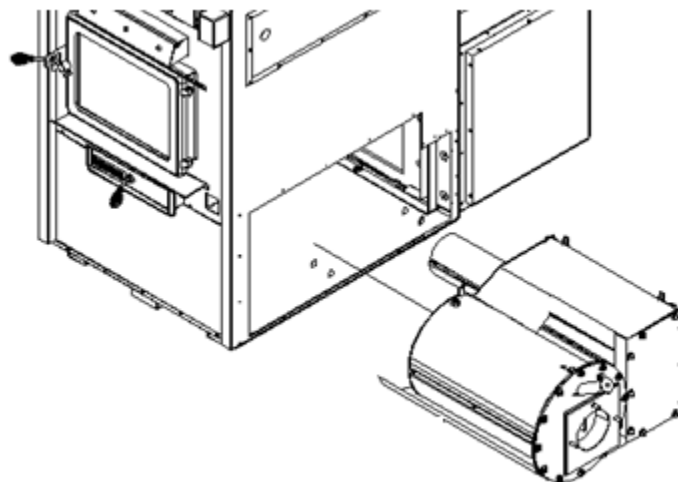

Step 5. Use the bolts on each side of the oil unit to have it leveled.

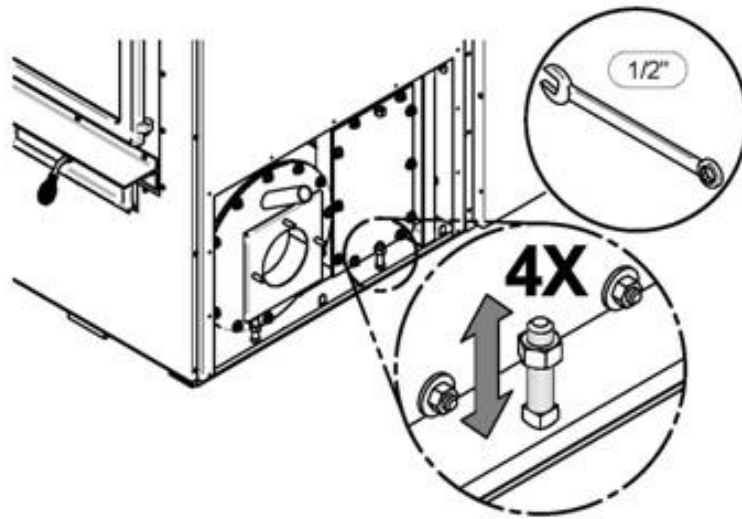

Step 6. Cut and install the gasket on the left and right panels provided with the oil unit.

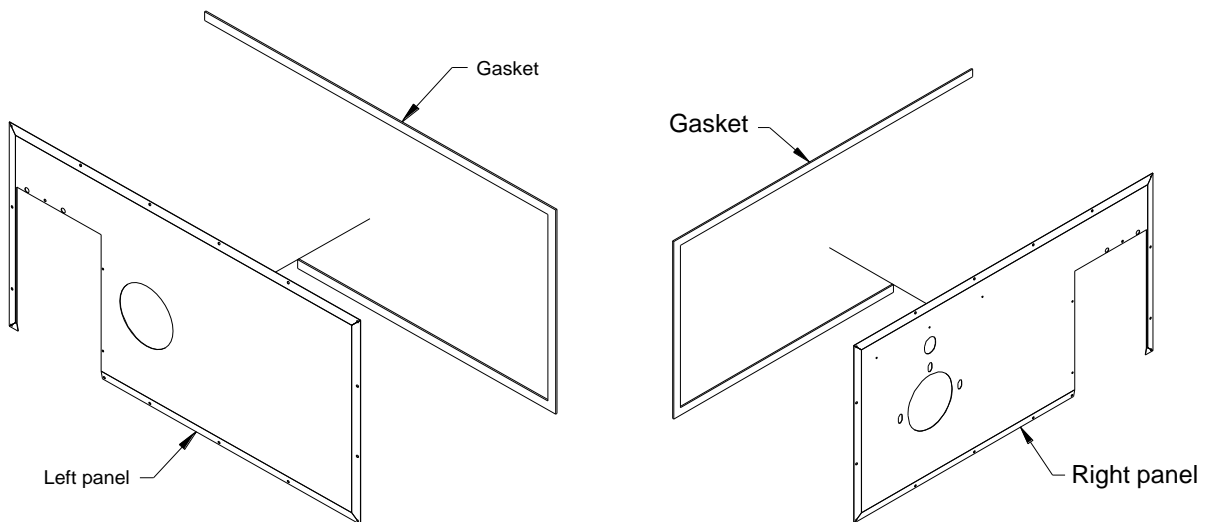

Step 7. Install the gasket on the oil unit combustion chamber cover. Then install the right panel from **Step 6** and the right electric element lid with the screws (22X) removed from **Step 1**.

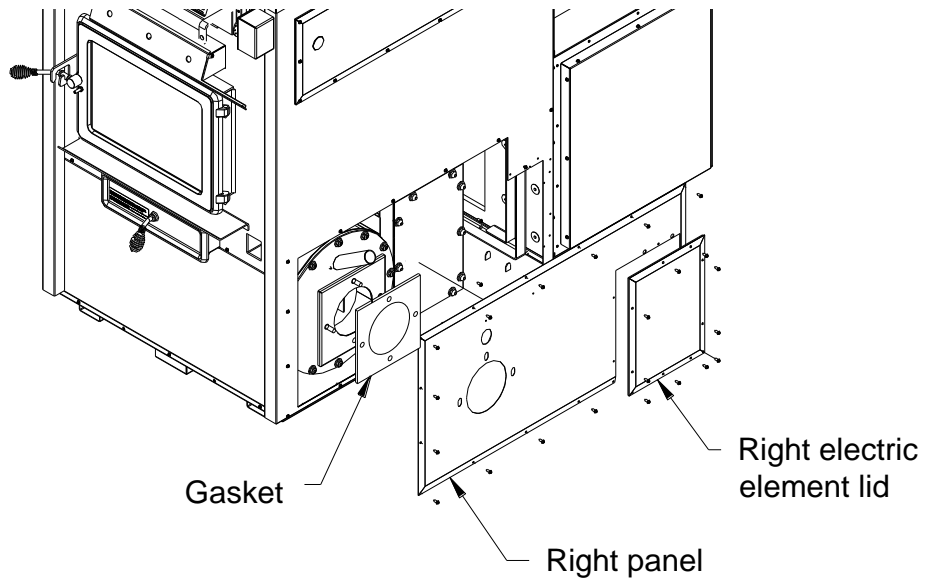

Step 8. Put the view tube cap back in place. Secure the oil unit using nuts and washers supplied with the option as shown. Install the certification label next to the oil unit.

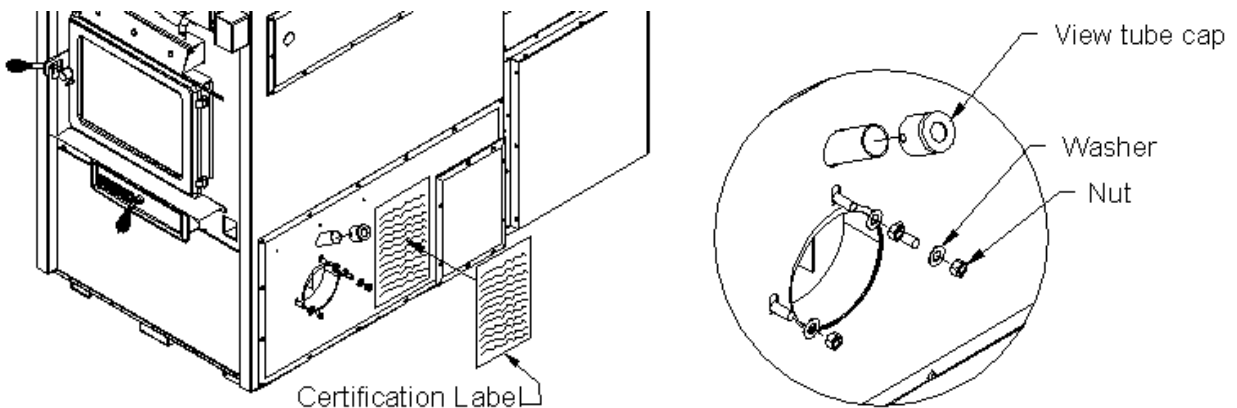

Step 9. Secure the left panel with the gasket installed in **Step 6** using the screws. Secure the left electric element lid back in place.

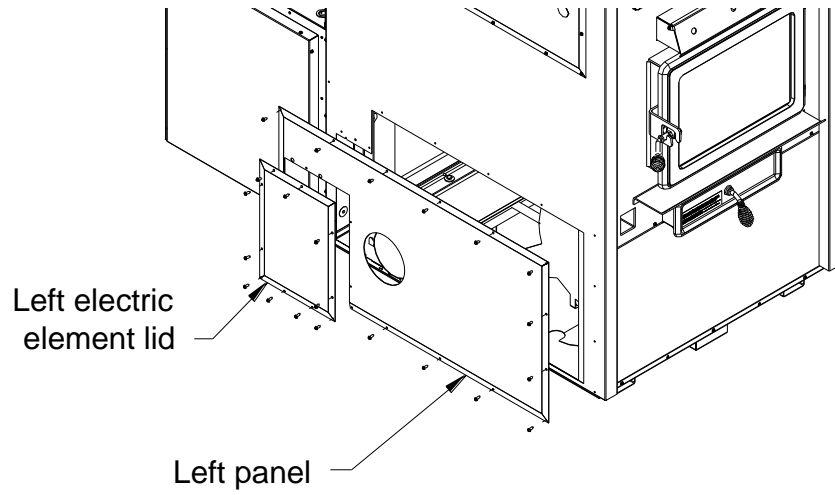

Step 10. In order to access the power board, remove the filter support assembly, if necessary.

Note: The duct support assembly location may differ depending on the chosen configuration when installing the blower box.

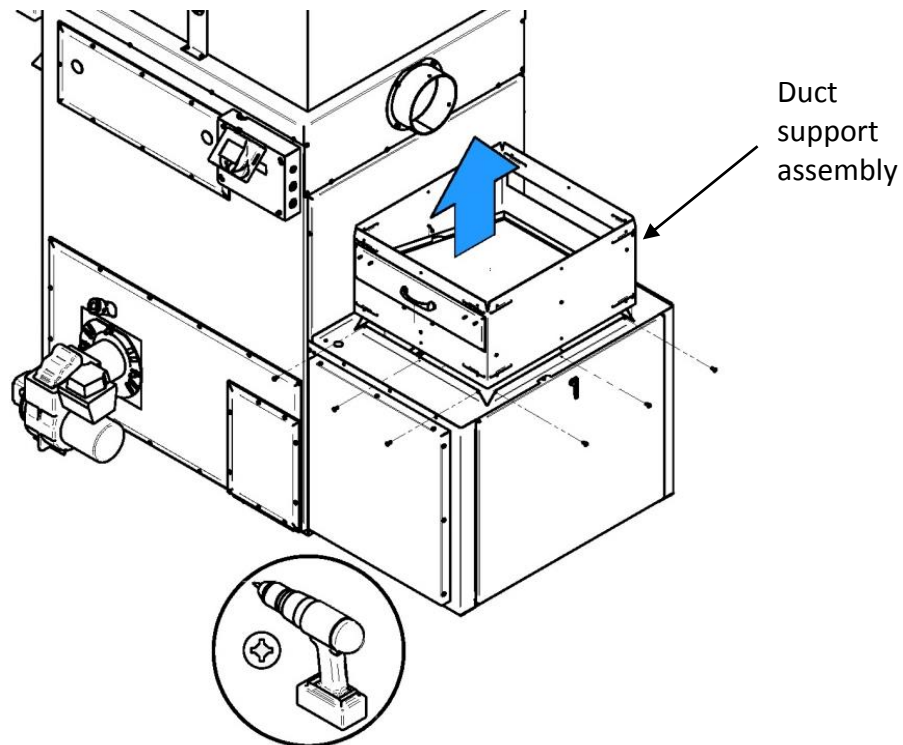

Step 11. Make the electrical connections according to the ***“Electrical connections”*** section.

Step 12. Reinstall the duct support assembly on the blower box with screws previously removed on **Step 10**.

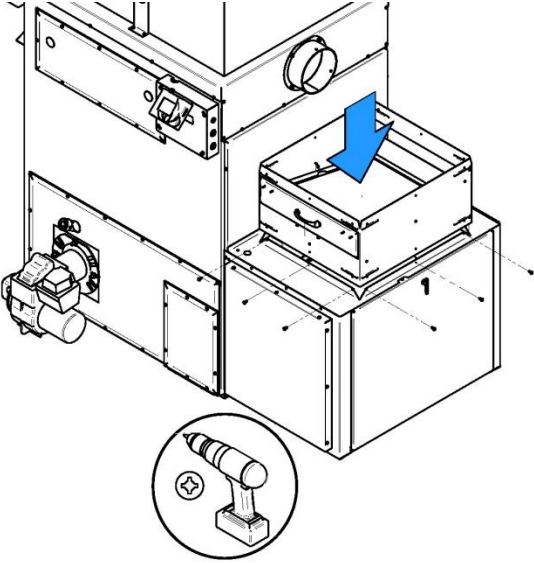

SECTION 2 - ELECTRICAL CONNECTIONS

BECKETT BURNER

Step 1. Use one cable with two conductors 18 gage (18/2) (not included).

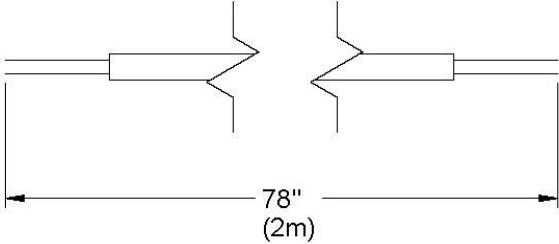

Step 2. Remove the screw that holds the power board cover located in the blower box. Connect the two wires on the **Tw** and **Tr** terminals of the oil unit primary control and pass them through the middle grommet of the furnace. Connect the wires of the oil unit on the "**OIL**" terminal on the power board.

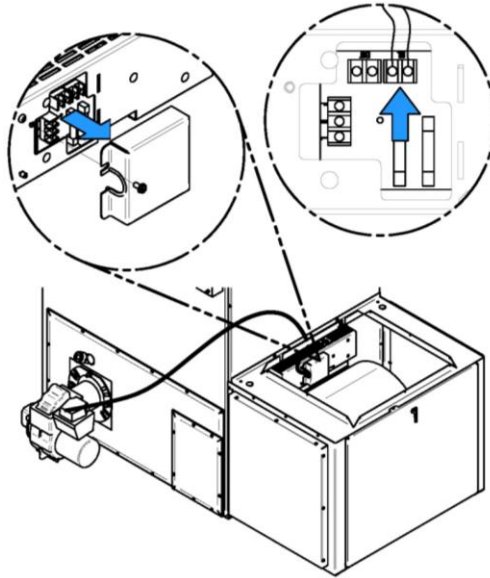

To facilitate connections, the use of a junction box is recommended. It can be installed on the back of the furnace. Use the following diagram for reference. Refer to the wiring diagram for complete connections.

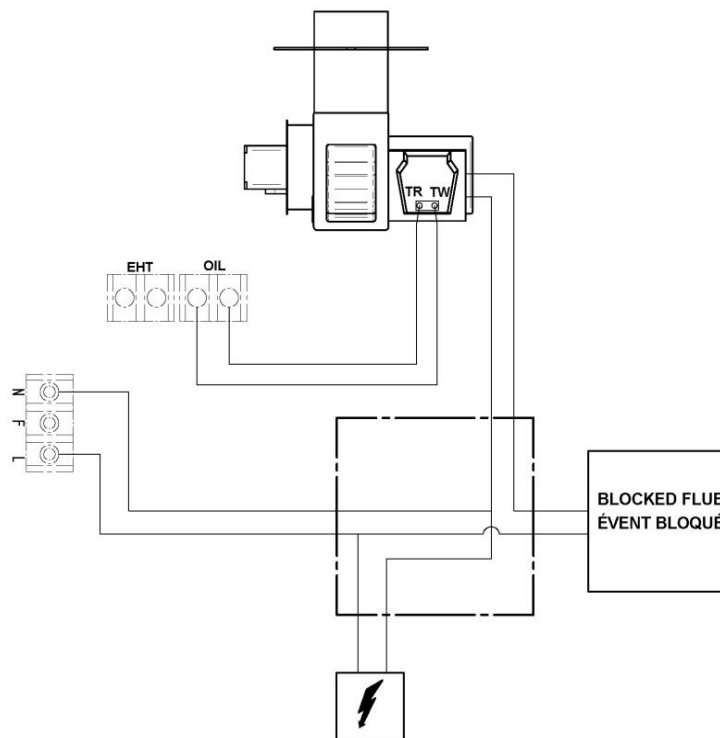

RIELLO BURNER

Step 1. Remove the blower box knockouts on both sides of the blower box. Install a grommet or a connector (not included).

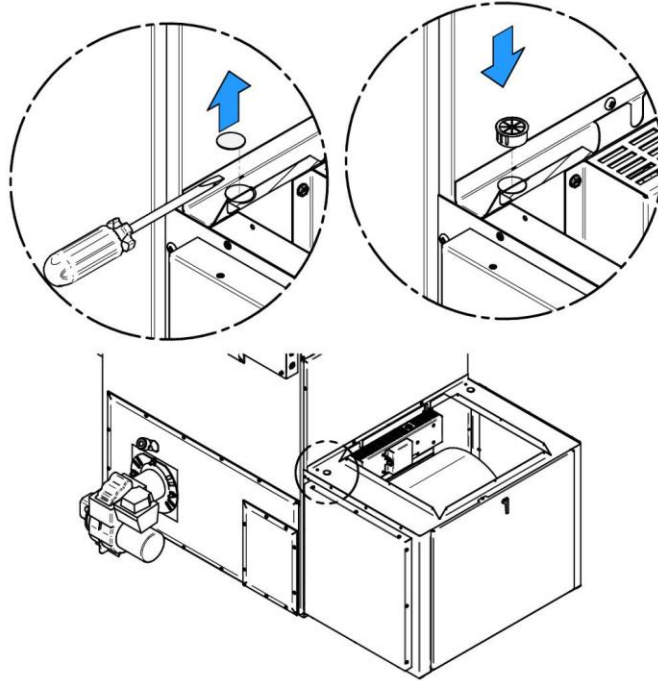

Step 2. Remove the screw that holds the power board cover which is found inside the blower box.

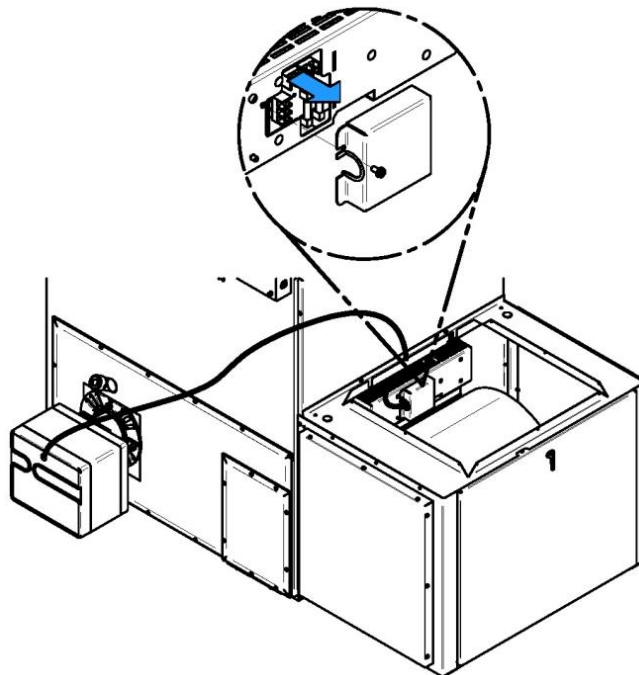

To facilitate connections, the use of a junction box is recommended. It can be installed on the back of the furnace. Use the following diagram for reference. Refer to the wiring diagram for complete connections.

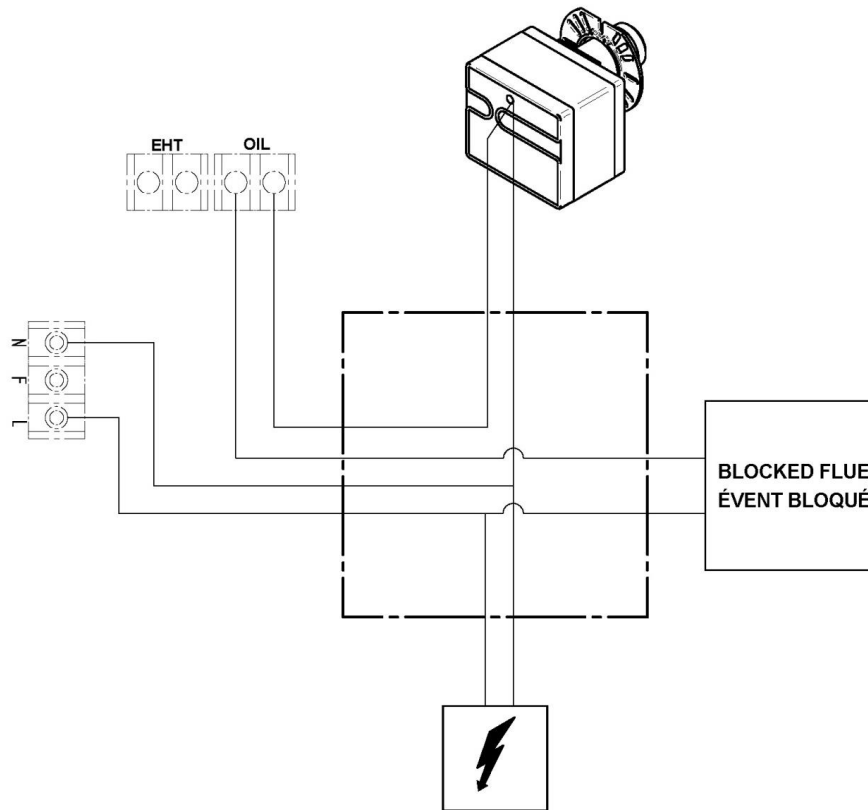

ADDITIONAL STEPS FOR LEFT SIDE INSTALLATION

Note: Replace Step 2 of the installation by the 2 following steps. When all steps are completed, continue installation at Step 3.

Step 2.1: Remove the deflector support, the oil burner support and the view tube cap. The deflector support is secured by screws while the burner support is secured by nuts and washers. Keep the screws and the nuts. Make sure that the gaskets stay in place when the oil burner support is removed.

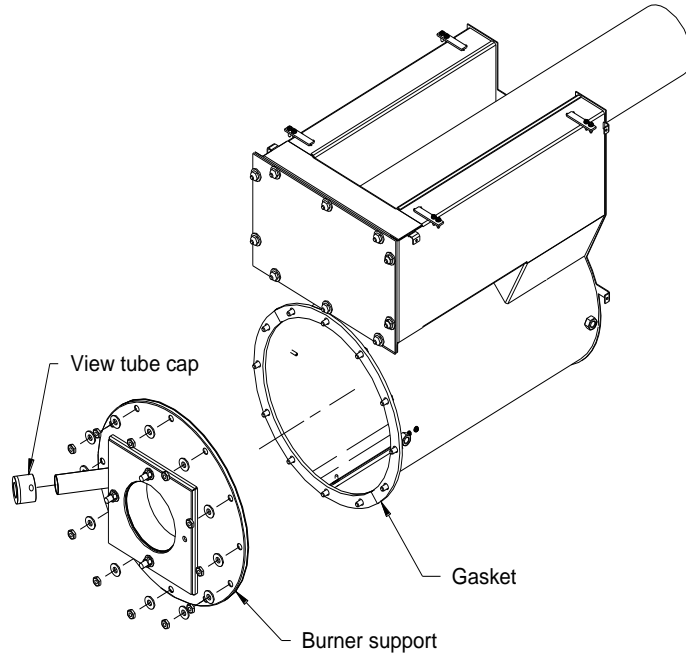

Step 2.2: Rotate 180 degrees the parts removed in **Step 2.1**. In order to do so, first install the gasket on the firebox of the oil unit. Then, secure the burner support onto the firebox using the nuts and washers. Remove the screws already secured to the firebox and use them to install the deflector support onto the firebox. Install the deflector and secure it in place using 4 screws. The screws and the deflector are supplied with the oil unit.

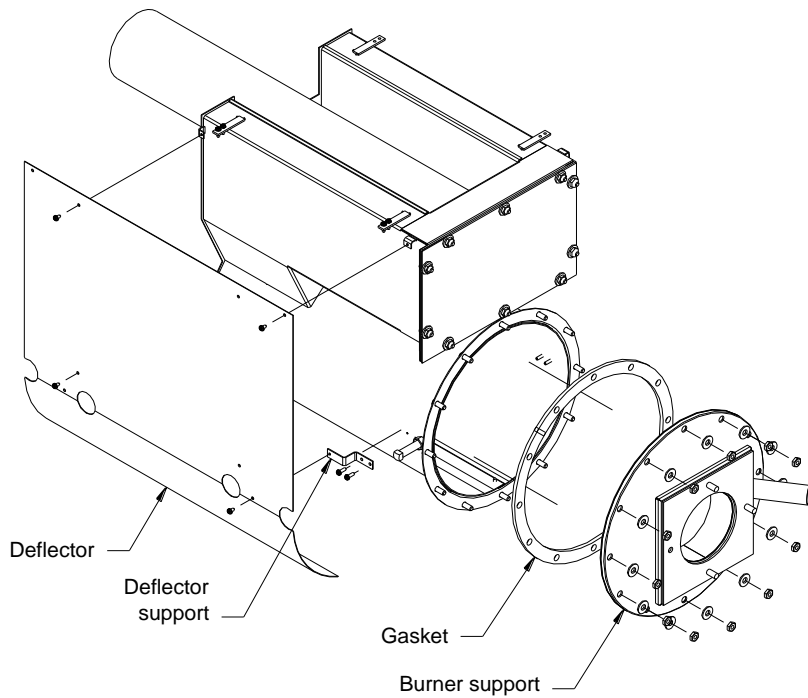

Technical data – Oil unit

MODEL	BURNER TYPE	BTU INPUT	NOZZLE	FLOW	HEAD	STATIC PLATE	PRESSURE AT THE PUMP	H.P. FAN MOTOR	TUBULATOR ADJUSTMENT	AIR ADJUSTMENT	EFFICIENCY
UH-MAX CADDY	BECKETT AFG	91,000	0.65, 70 ^o W (DELAVAN)	0.65 GAL US/H (2.46 L-H)	F0	---	100 PSI (690 kPa)	1/2	---	0/7	85%
UH-MAX CADDY	BECKETT AFG	120,000	0.65, 70 ^o W (DELAVAN)	0.86 GAL US/H (3.26 L-H)	F0	---	175 PSI (1205 kPa)	1/2	---	1/6	83%
UH-MAX CADDY	RIELLO 40 F3	91,000	0.50, 70 ^o W (DELAVAN)	0.60 GAL US/H (2.27 L-H)	---	---	150 PSI (1035 kPa)	1/2	1	2.5	87%
UH-MAX CADDY	RIELLO 40 F3	120,000	0.65, 70 ^o W (DELAVAN)	0.84 GAL US/H (3.18 L-H)	---	---	165 PSI (1135 kPa)	1/2	1	2.5	85%

BLOCKED VENT SWITCH

A Blocked Vent Switch is mandatory for installation with an oil-fired appliance that normally operates with its vent system under a negative pressure. This device is intended to detect a blocked vent system, responds to hot flue gases backing up through its heat transfer tube, and can be wired to shut off the oil burner. It requires manual resetting.



WIRING DIAGRAM – BECKETT BURNER

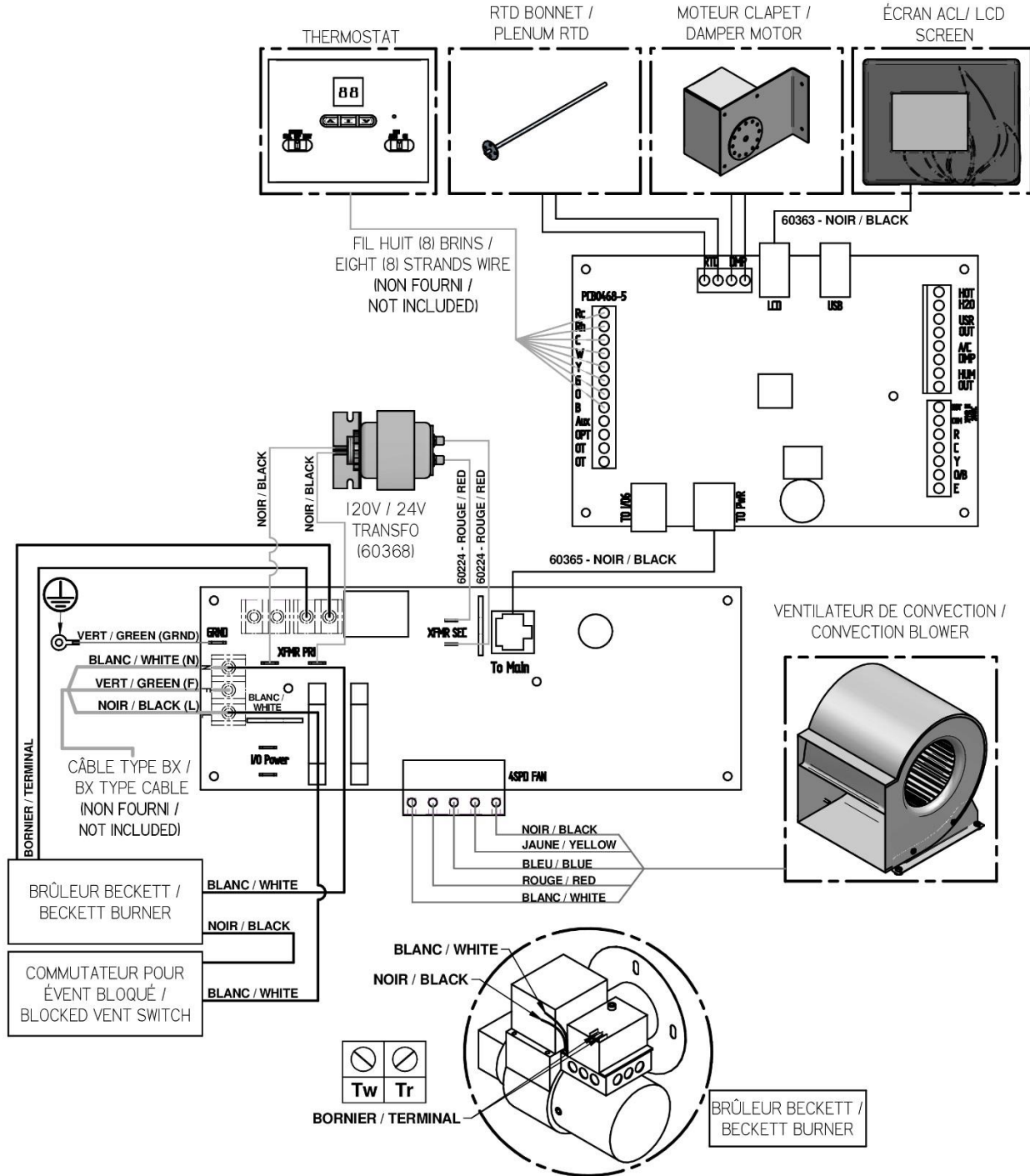

WIRING DIAGRAM – RIELLO BURNER

