

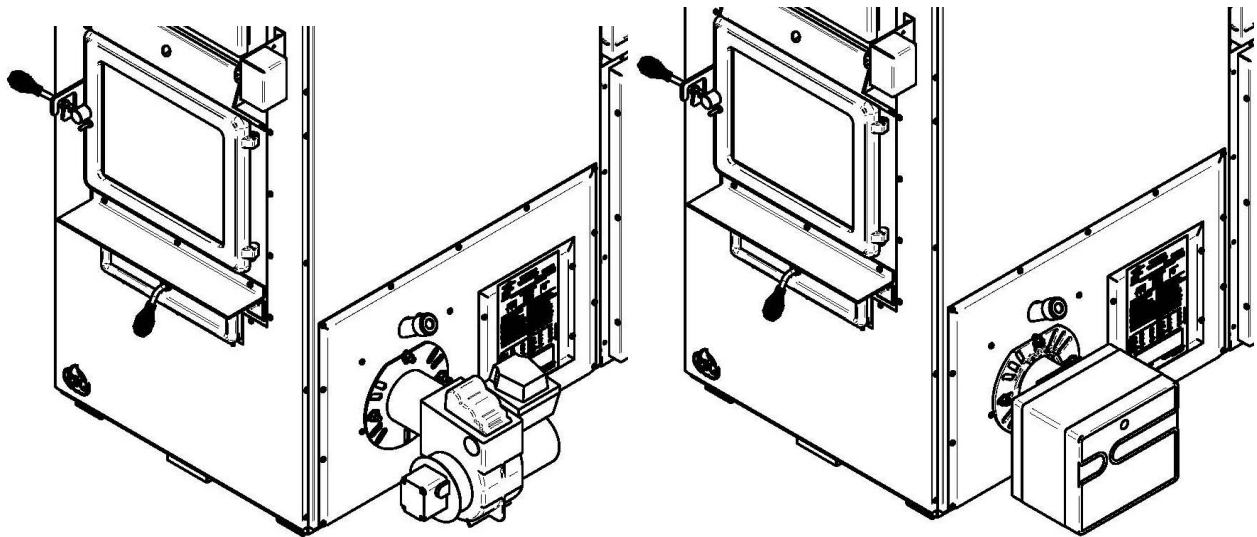

OPTIONAL OIL UNIT INSTALLATION (PA03055 or PA03105)

CADDY FURNACE



**WARNING: INSTALL THE NOZZLE, ADJUST THE ELECTRODES,
ADJUST PRESSURE ACCORDING TO THE OIL UNIT
MANUFACTURER'S RECOMMENDATIONS.**

**NOTE: IF A PROBLEM RESULTS FROM IMPROPER INSTALLATION,
NO PRODUCT WARRANTY WILL BE VALID.**

Verified and tested for
Canada and the United
States by an accredited
laboratory.



This manual is available for free download on the manufacturer's web site. It is a copyrighted document. Resale is strictly prohibited. The manufacturer may update this manual from time to time and cannot be responsible for problems, injuries, or damages arising out of the use of information contained in any manual obtained from unauthorized sources.



***Eco-energy at the hearth
of your home***

PSG
250, rue de Copenhague,
St-Augustin-de-Desmaures (Québec)
CANADA G3A 2H3

Your Caddy furnace can be equipped with an optional oil unit. This option can be installed on either side of your furnace. It is important to note that the default configuration of your furnace features the oil unit installed on the right side of your furnace. It is possible to install the oil unit on the left side but requires additional steps.

*Please note that the installation on the furnace is carried out in an identical way for both Beckett and Riello units. For electrical connections, refer to “**Electrical connections**” section.*

Installation must be performed by a qualified technician.

SECTION 1 - INSTALLATION INSTRUCTIONS

Step 1. Remove the left panel (A) and the right panel (B) of the furnace by removing the screws that hold them in place (C) (22X). Keep the screws. Discard the panels.

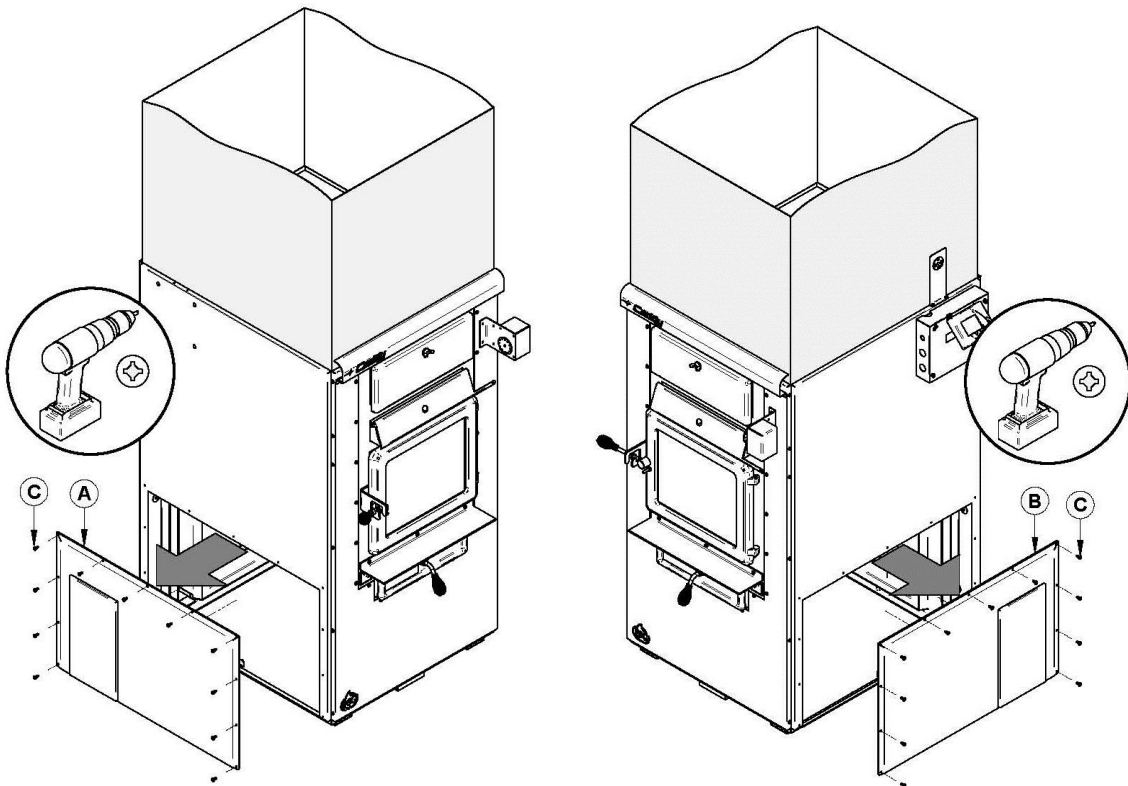

Step 2. Remove the right and left panels of the blower box (**D**) by removing the screws that hold them in place (**E**) (6X if the blower box wasn't already installed on the furnace, 18X if the blower box was already installed on the furnace). Keep the screws.

Note: The duct support assembly location may differ depending on the chosen configuration when installing the blower box.

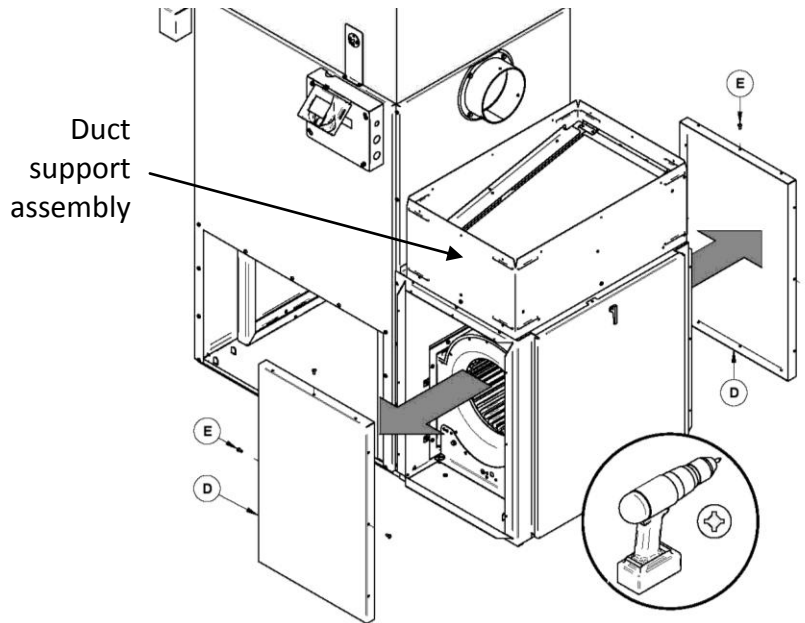

Step 3. Remove the deflector (**G**) inside the furnace by removing the screws (**F**) (4X) located in the blower box (two on each side).

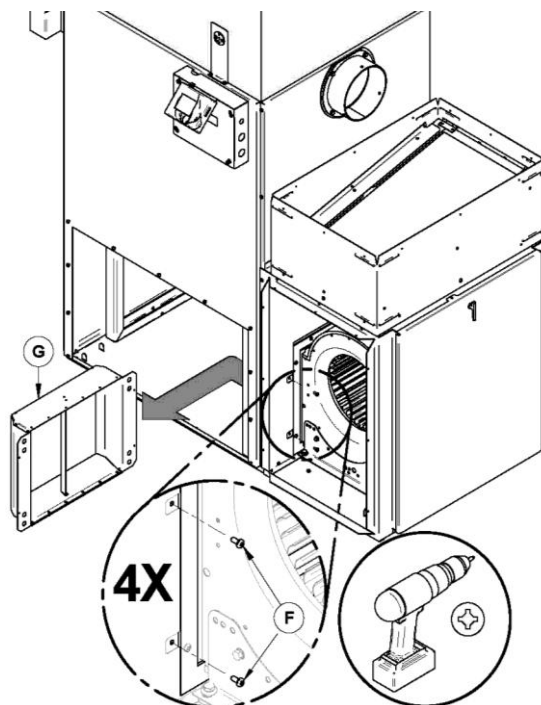

Step 4. Replace the right and left blower box panels (D) with screws (E) (18X). (Note: If the blower box wasn't already installed on the furnace, the missing screws (12X) can be found in the blower box user's manual kit).

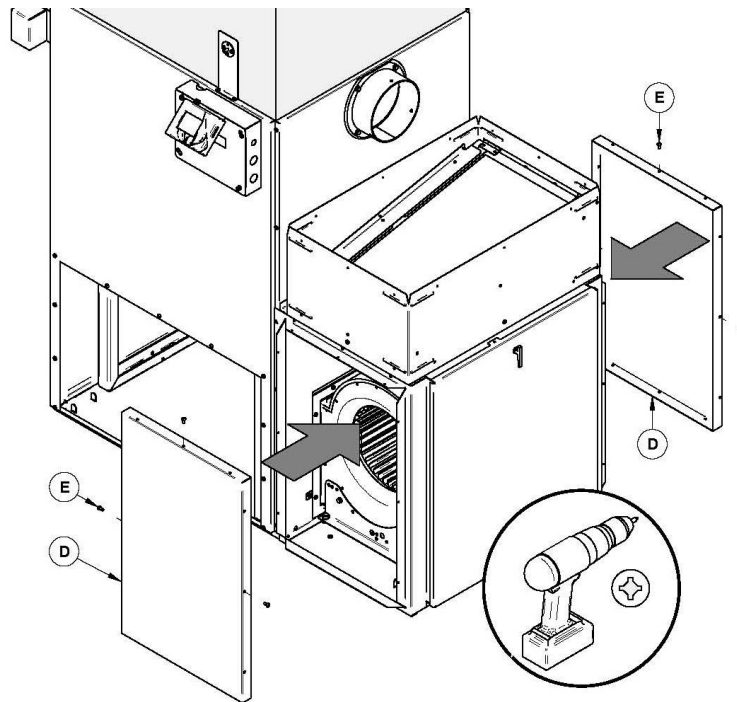

Note: To install the oil unit on the left side of the furnace, replace Step 5 by the Section *“additional steps for left side installation”*. Continue the installation from Step 6.

Step 5. Install the deflector (H) on the oil unit with the screws (I) (4X) provided with it. Then install the bolts (J) (4X) in the nuts located on the oil unit combustion chamber.

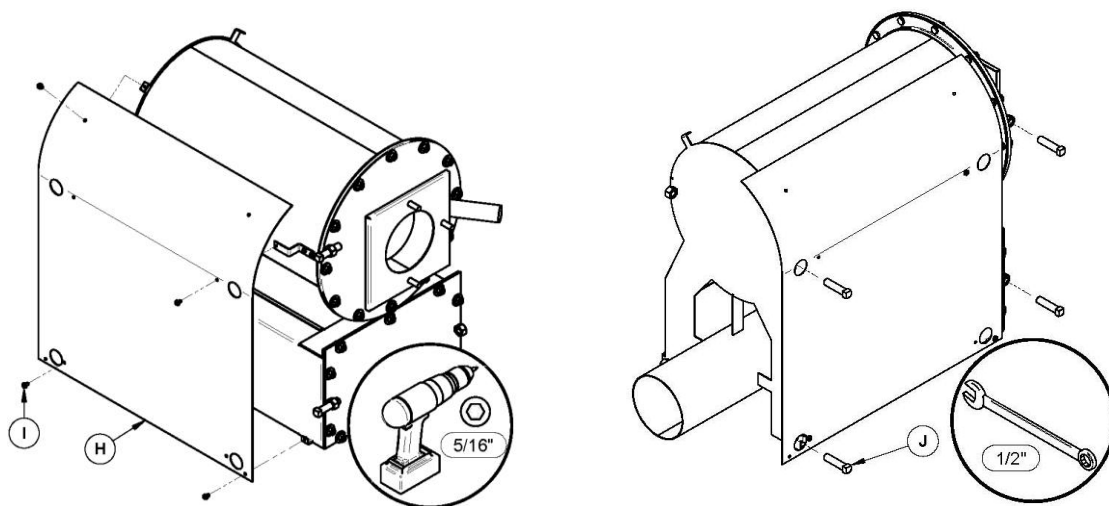

Step 6. Remove the vision tube cap.

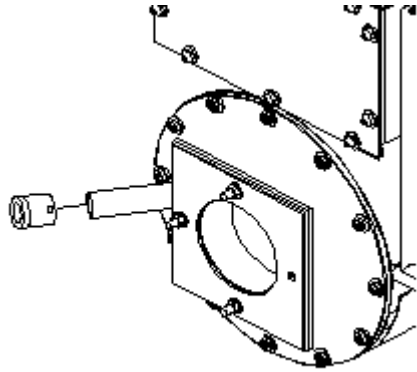

Step 7. Slide the oil unit (R) in the furnace.

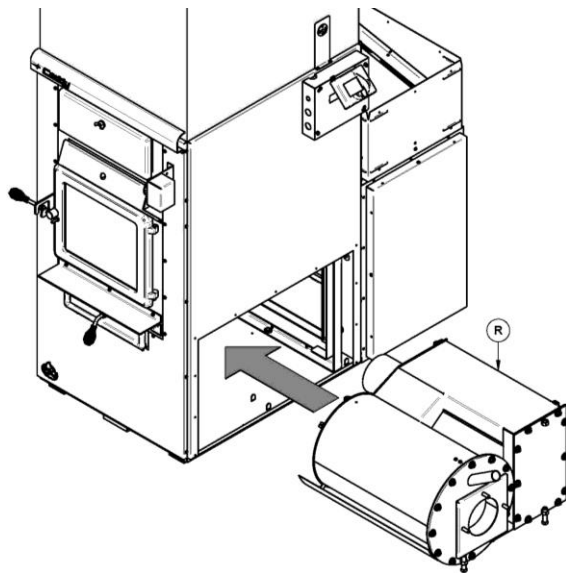

Step 8. Use the bolts (F) on each side of the oil unit to have it leveled.

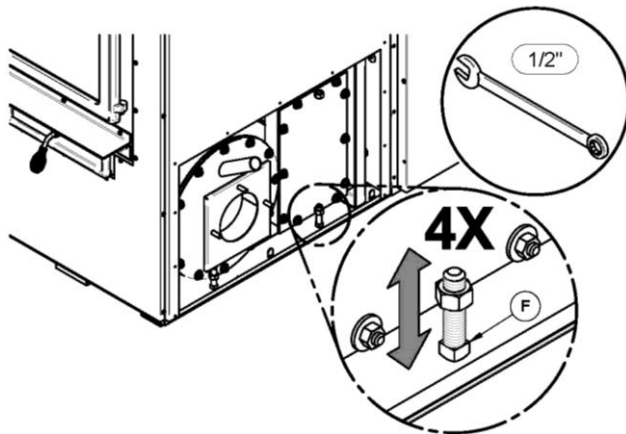

Step 9. Cut and install the gasket (**T**) on the left panel (**S**), the right panel (**U**) and the air jacket panels (**V**) (2X) of the furnace according to the following measurements:

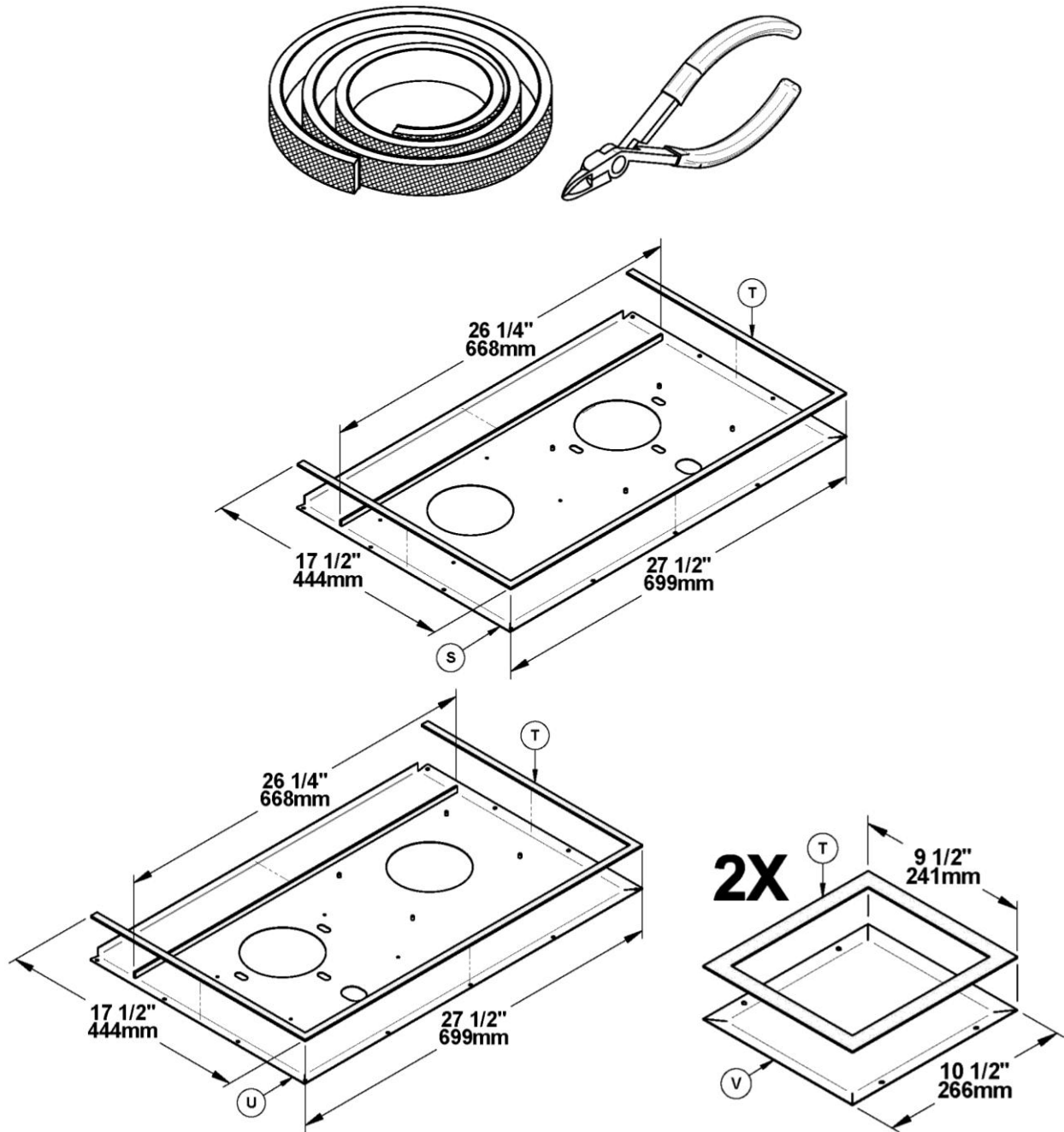

Step 10. Install the air jacket panels (**V**) (2X) on the left (**S**) and right (**U**) panel with the screws (**W**) (8X).

Note: For a left side installation, see “**Additional steps for left side installation**” for directions on which sides to install the air jacket panels.

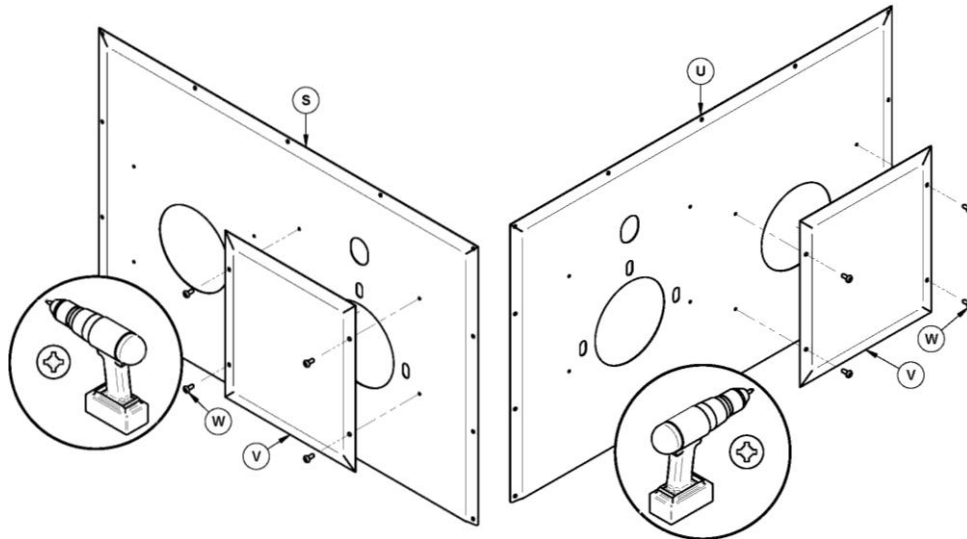

Step 11. Install the left panel (**S**) on the furnace. Secure it with the screws (**C**) (11X) removed from **Step 1**. Plug the panel holes with the screws provided with the oil unit.

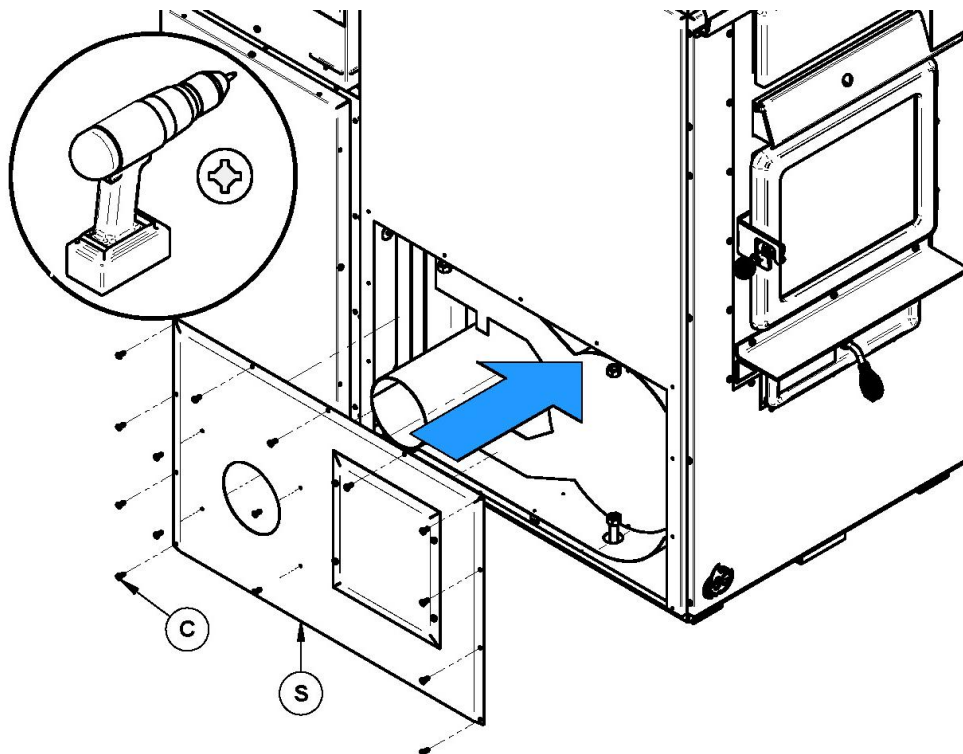

Step 12. Install the gasket (X) on the oil unit combustion chamber cover. Then install the right panel (U) with the screws (C) (11X) removed from **Step 1**.

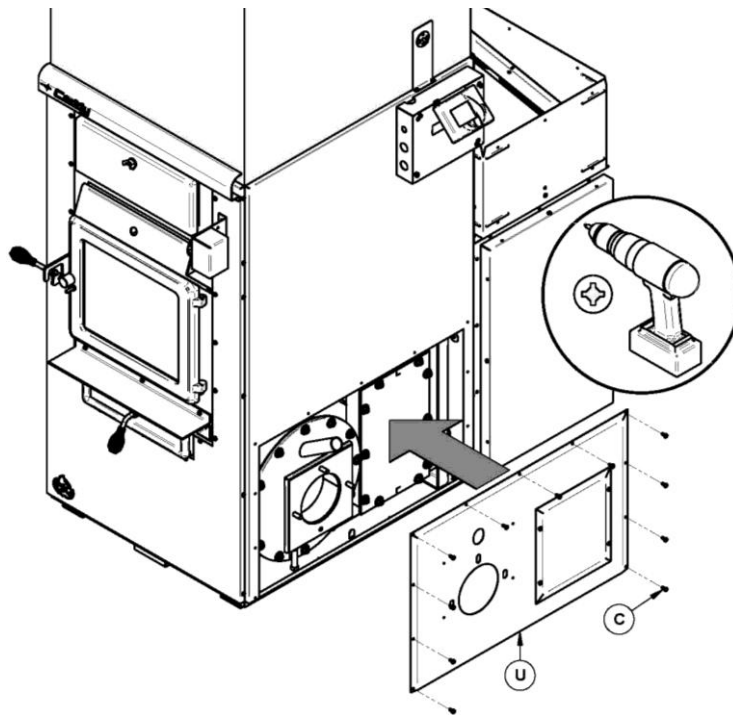
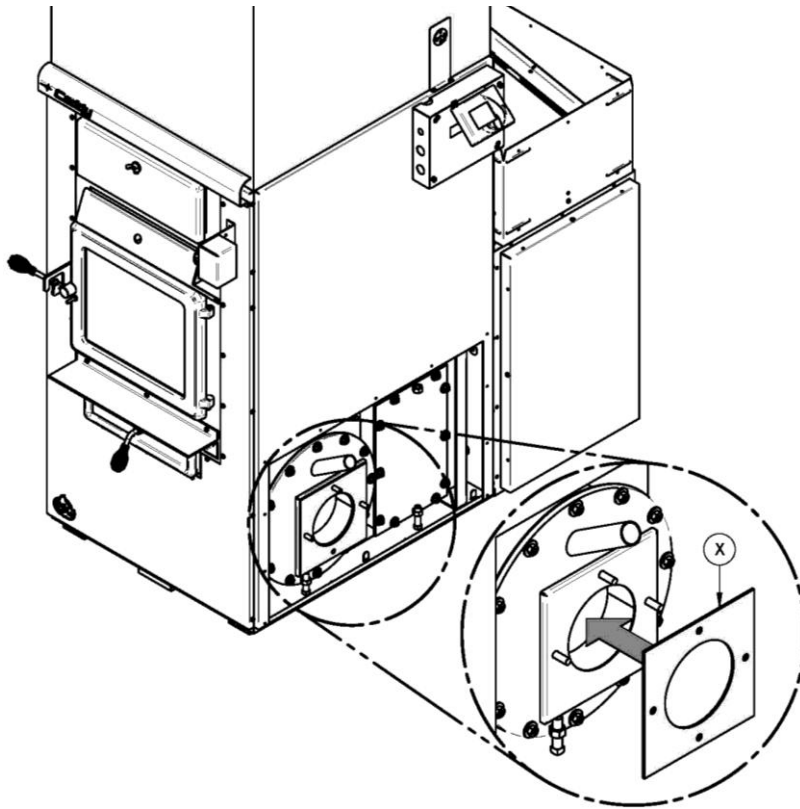

Step 13. Install 4 screws (**W**) on the right side panel to plug the holes.

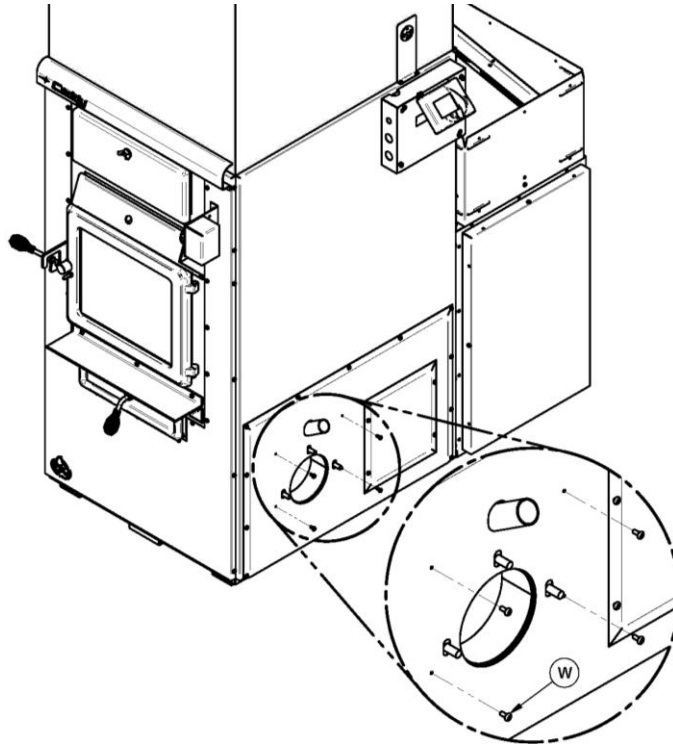

Step 14. Install the burner (**AA**). Secure it with washers (**Y**) (3X) and nuts (**Z**) (3X) (**Beckett unit**).

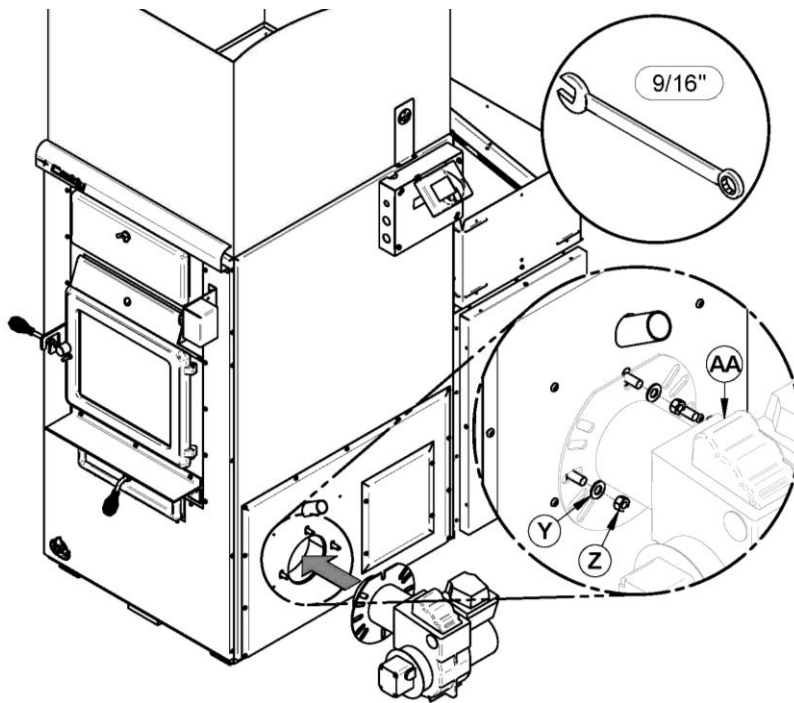

Install the burner (BB). Secure it with washers (Y) (3X) and nuts (Z) (3X) (Riello unit).

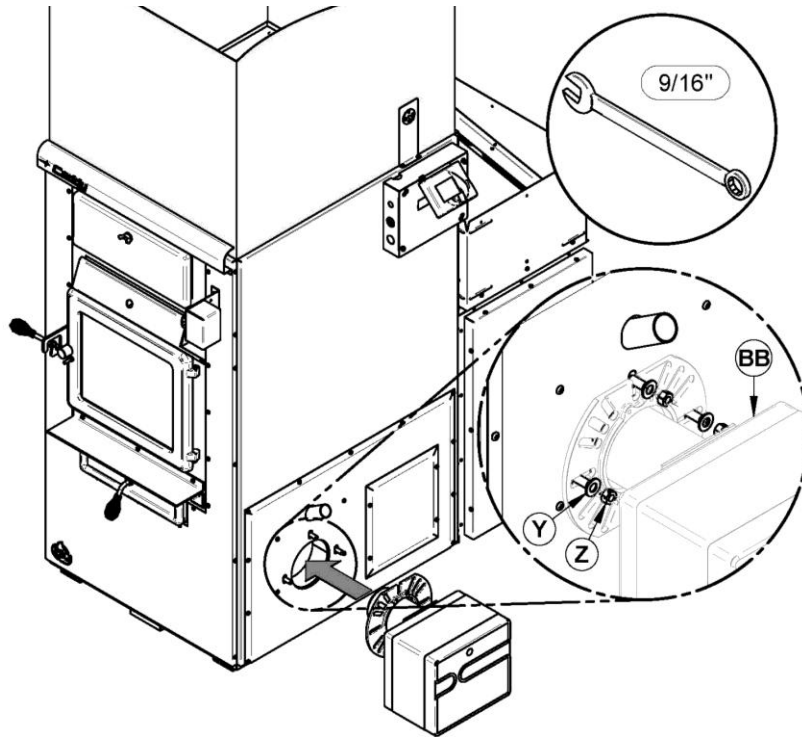

Step 15. Install and secure the sealed vision cap (CC) with the set screw (DD).

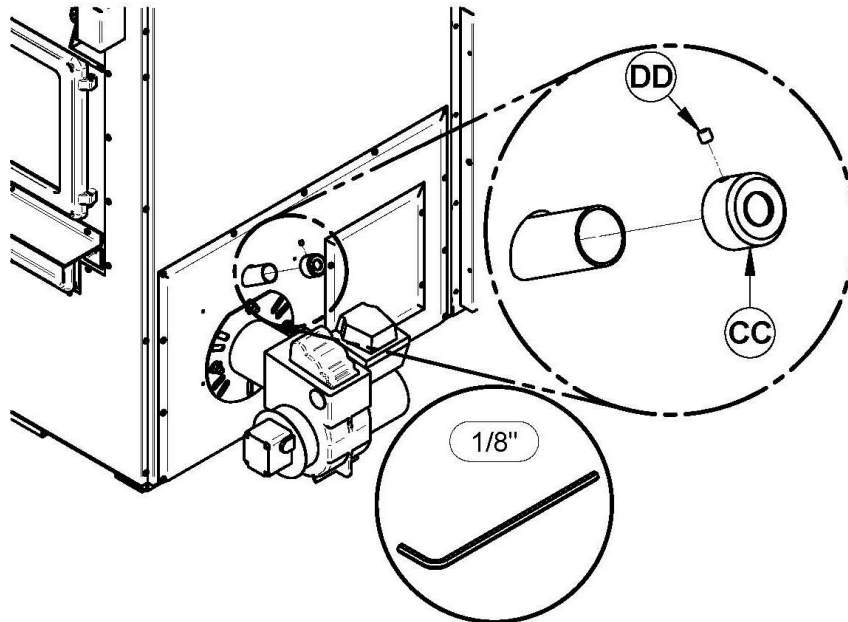

Step 16. Install the certification label (**EE**) on the air jacket panel.

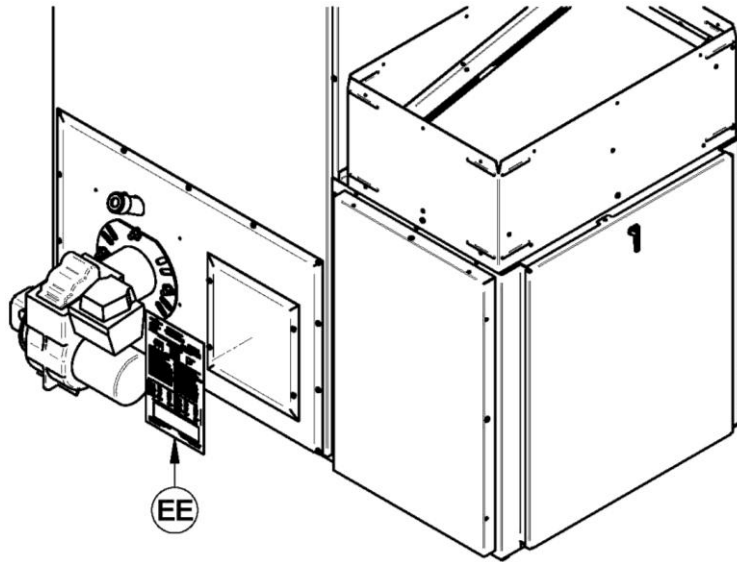

Step 17. In order to access the power board, remove the filter support assembly (**FF**) held in place with screws (**GG**) (9X), if necessary.

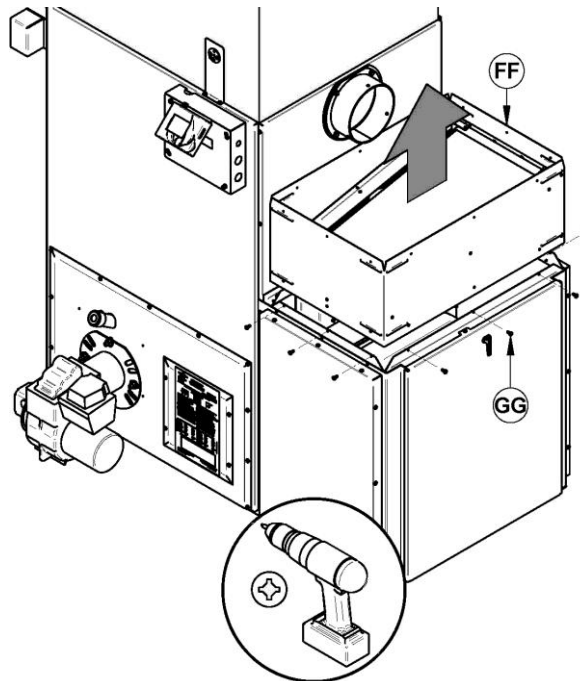

Step 18. Make the electrical connections according to the “*Electrical connections*” section

Step 19. Reinstall the filter support assembly (**FF**) on the blower box with screws (**GG**) (9X) previously removed on **Step 17**.

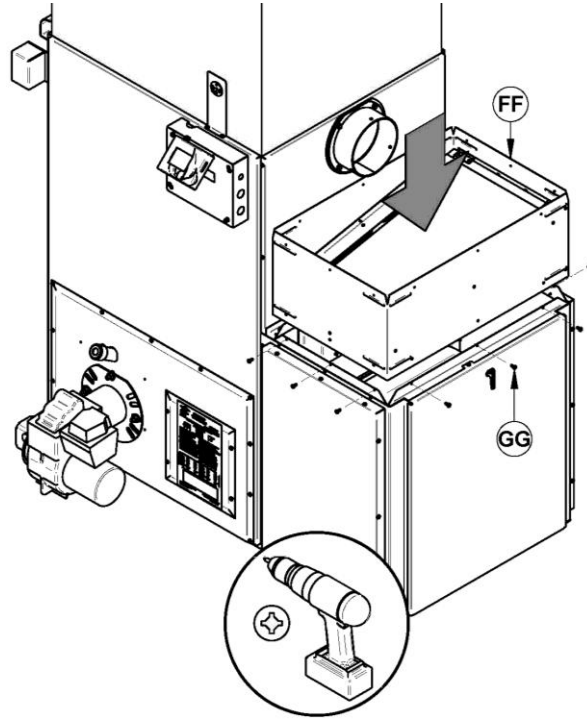

SECTION 2 - ELECTRICAL CONNECTIONS

BECKETT BURNER

Step 1. Use one cable with two conductors 18 gage (18/2) (not included).

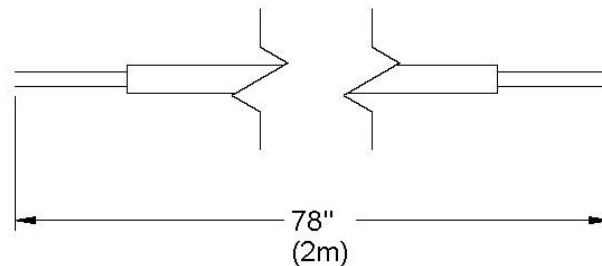

Step 2. Remove the screw **(LL)** that holds the power board cover **(KK)** located in the blower box **(Detail 3)** Connect the two wires on the Tw and Tr terminals of the oil unit primary control and pass them through the middle grommet of the blower box and connect the wires of the oil unit on the "OIL" terminal on the power board **(Detail 4)**

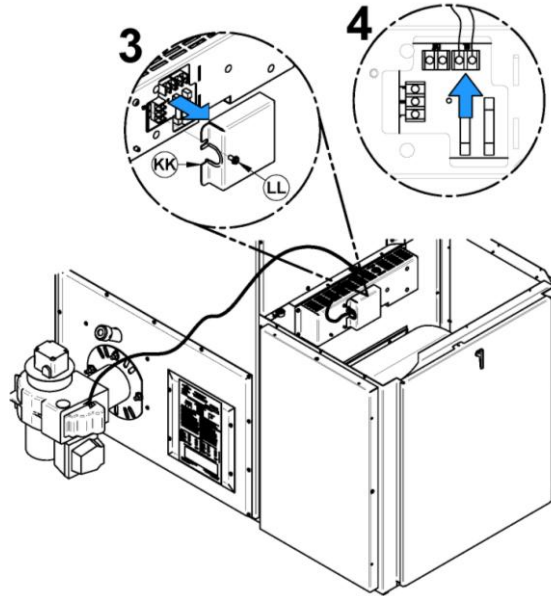

To facilitate connections, the use of a junction box is recommended. It can be installed on the back of the furnace. Use the following diagram for reference. Refer to the wiring diagram for complete connections.

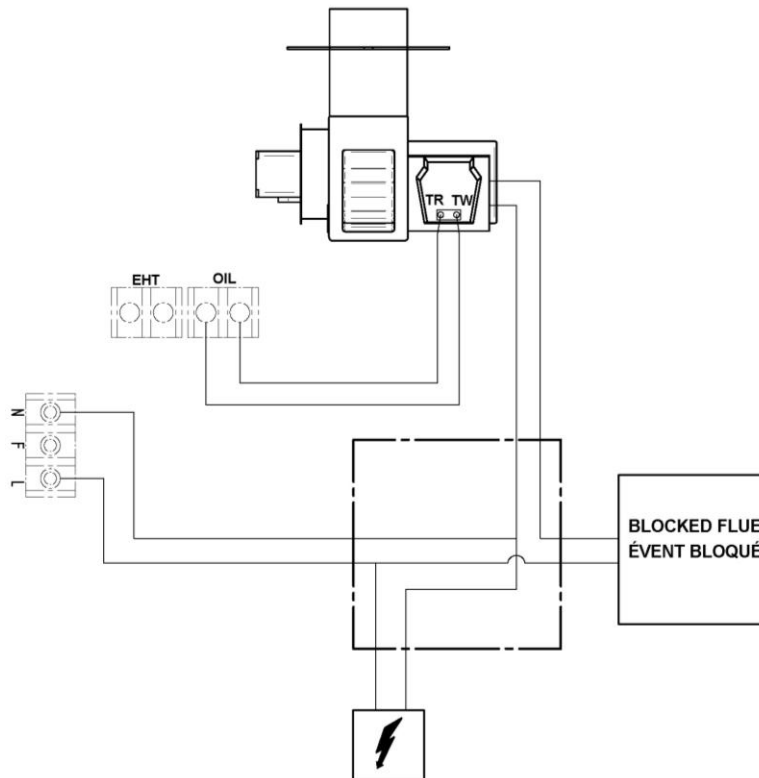

RIELLO BURNER

Step 1. Remove the two blower box knockout (**HH**) located on both sides of the blower box. (**Detail 1**). Install a grommet (**JJ**) or a connector (not included) (**Detail 2**).

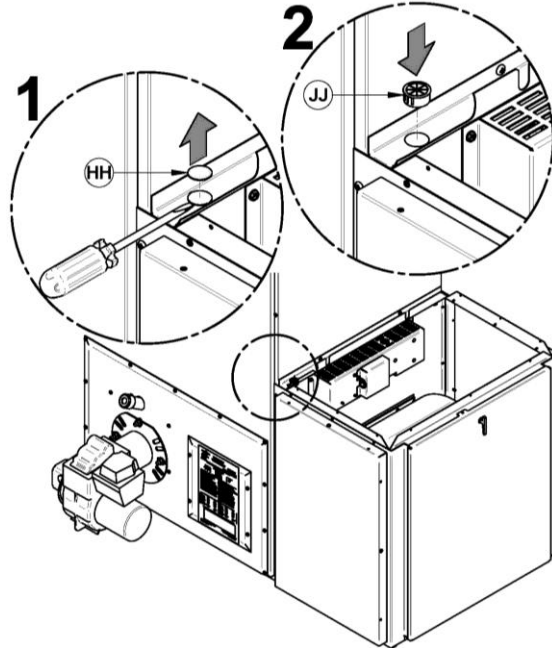

Step 2. Remove the screw (**LL**) that holds the power board cover (**KK**) located in the blower box.

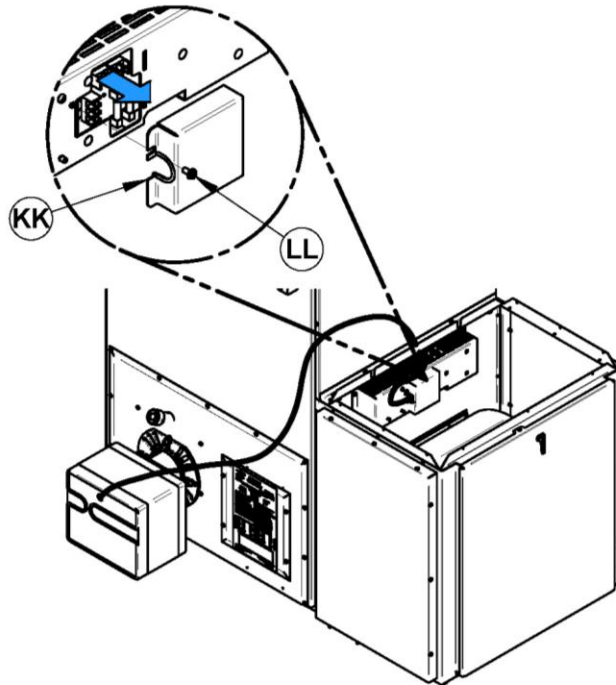

To facilitate connections, the use of a junction box is recommended. It can be installed on the back of the furnace. Use the following diagram for reference. Refer to the wiring diagram for complete connections.

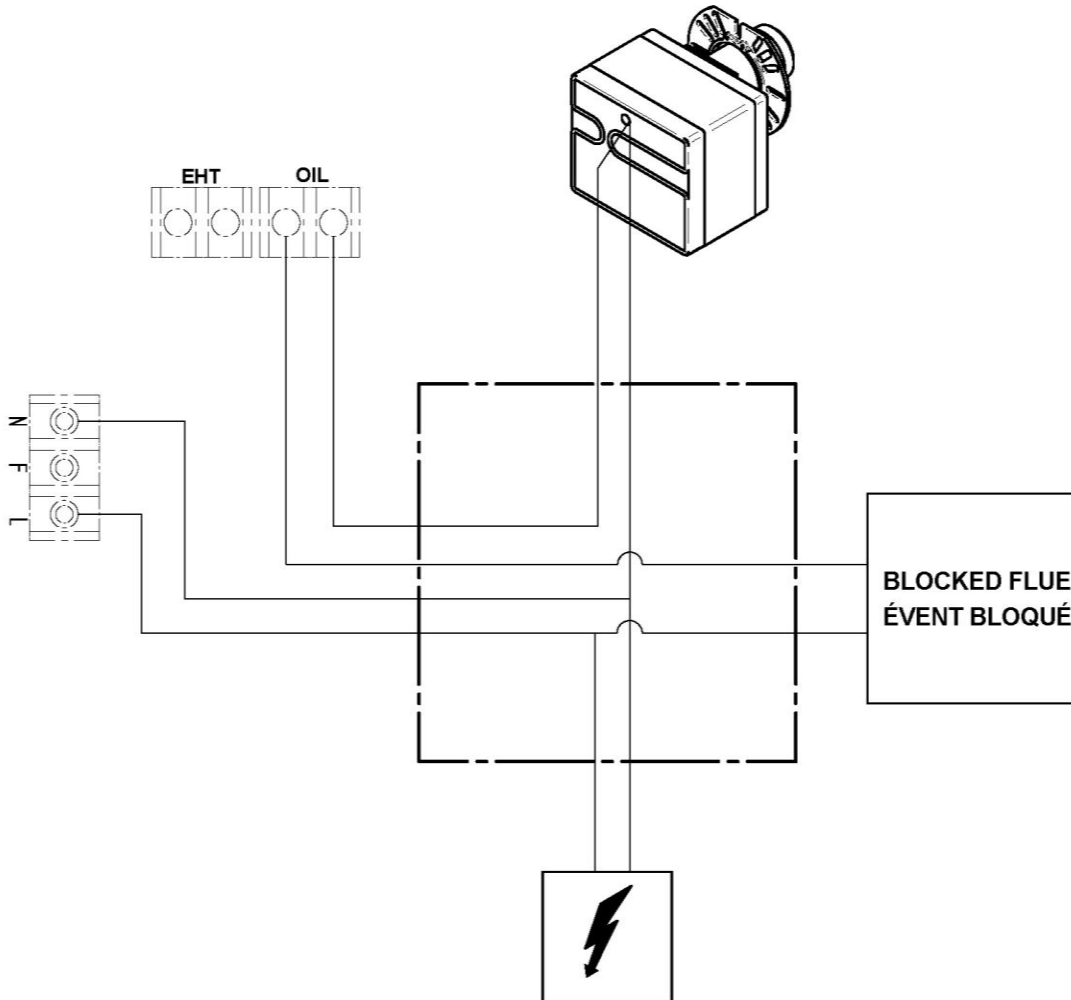

ADDITIONAL STEPS FOR LEFT SIDE INSTALLATION

Note: Replace Step 5 of the installation by the 4 following steps. When all steps are completed, continue installation at Step 6.

Step 5.1: Secure the support (K) with the existing screws (L) (2X) located on the top of the combustion chamber.

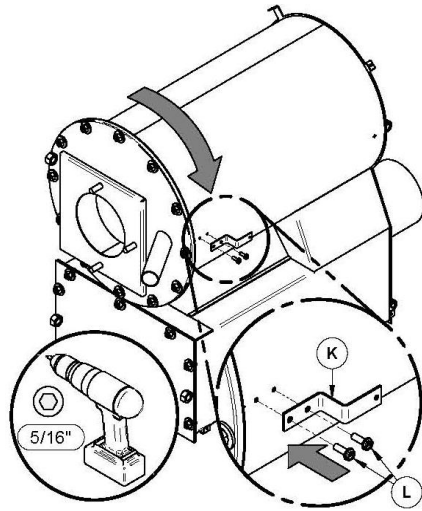

Step 5.2: Unscrew the bolts (M) (12X), washers (N) (12X) and nuts (O) (12X) located on the periphery of the combustion chamber cover. Carefully remove the combustion chamber cover (P) and the seal (Q). Turn the cover 180° and reinstall it with the seal. Secure it in place with the bolts, nuts and washers removed earlier.

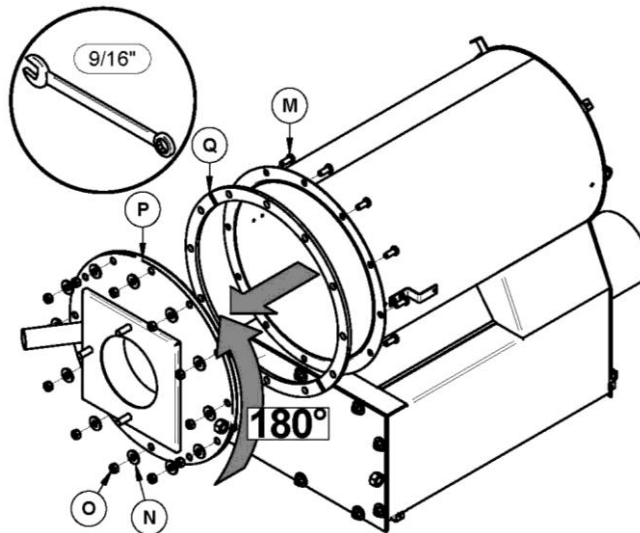

Step 5.3: Install the deflector (**H**) on the oil unit with the screws provided with it (**I**) (4X). Then fasten the bolts (**J**) (4X) to the nuts located on the oil unit combustion chamber.

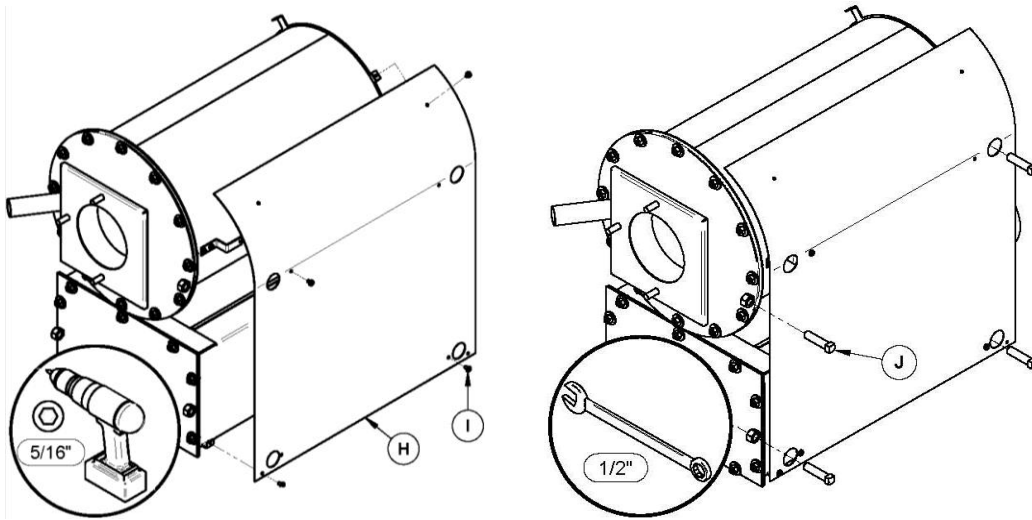

Step 5.4: Secure air jacket panels (**V**) (2X) using screws (**W**) (4X) on both panels (**S**) and (**U**).

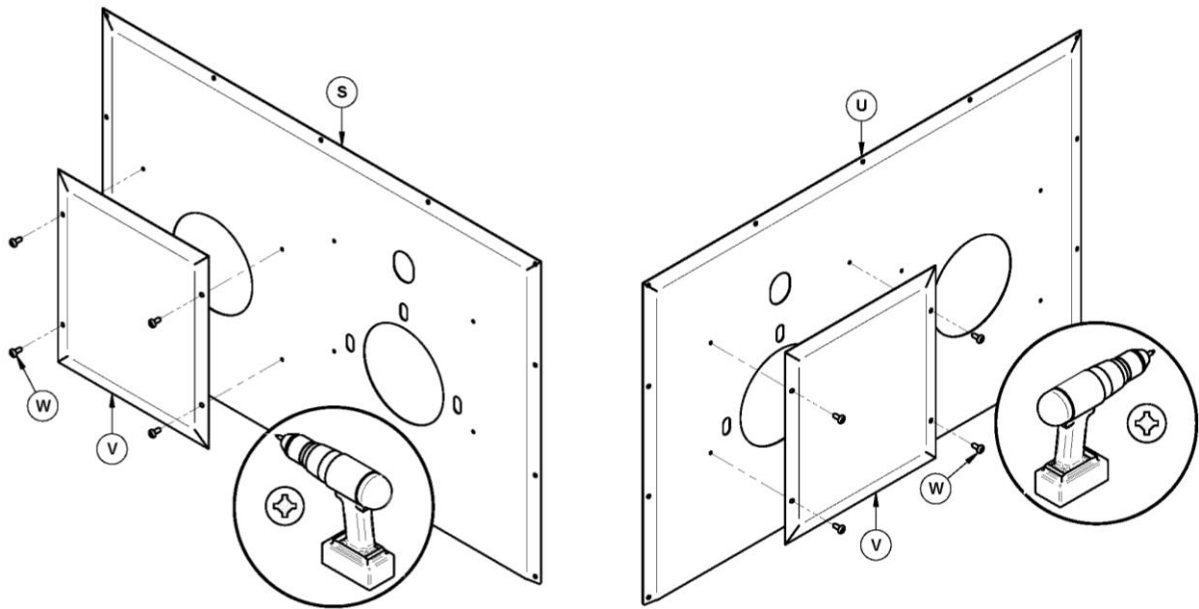

Technical data – Oil unit

MODEL	BURNER TYPE	BTU INPUT	NOZZLE	FLOW	HEAD	STATIC PLATE	PRESSURE AT THE PUMP	H.P. FAN MOTOR	TUBULATOR ADJUSTMENT	AIR ADJUSTMENT	EFFICIENCY
UH-CADDY	BECKETT AFG	91,000	0.65, 70 ⁰ W (DELAVAN)	0.65 GAL US/H (2.46 L-H)	F0	---	100 PSI (690 kPa)	1/3	---	0/4	85%
UH-CADDY	RIELLO 40 F3	91,000	0.50, 70 ⁰ W (DELAVAN)	0.60 GAL US/H (2.27 L-H)	---	---	150 PSI (1035 kPa)	1/3	1	2.5	87%

BLOCKED VENT SWITCH

A Blocked Vent Switch is mandatory for installation with an oil-fired appliance that normally operates with its vent system under a negative pressure. This device is intended to detect a blocked vent system, responds to hot flue gases backing up through its heat transfer tube, and can be wired to shut off the oil burner. It requires manual resetting.



WIRING DIAGRAM – BECKETT BURNER

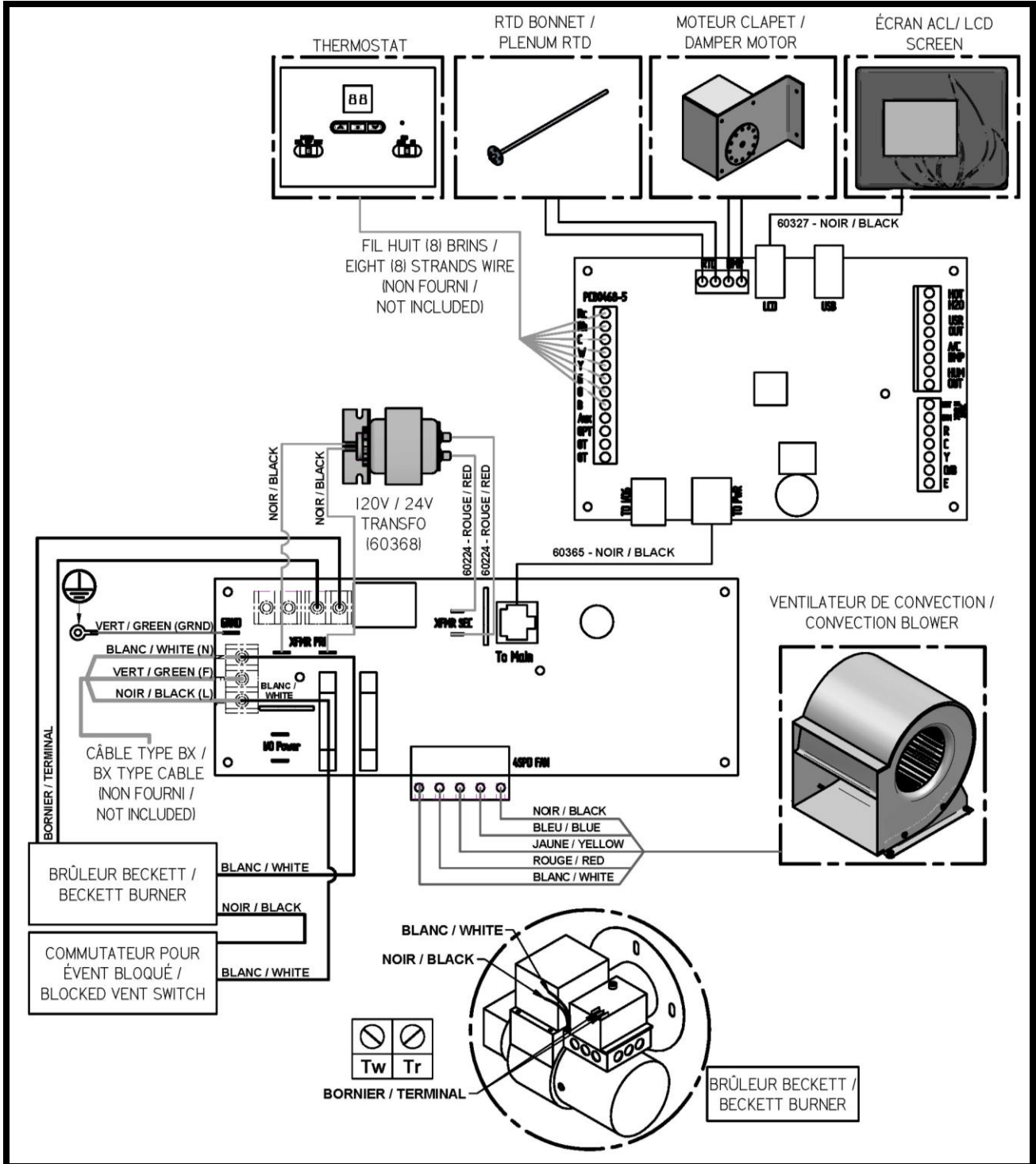

WIRING DIAGRAM – RIELLO BURNER

